

Machined Ring Needle Roller Bearings

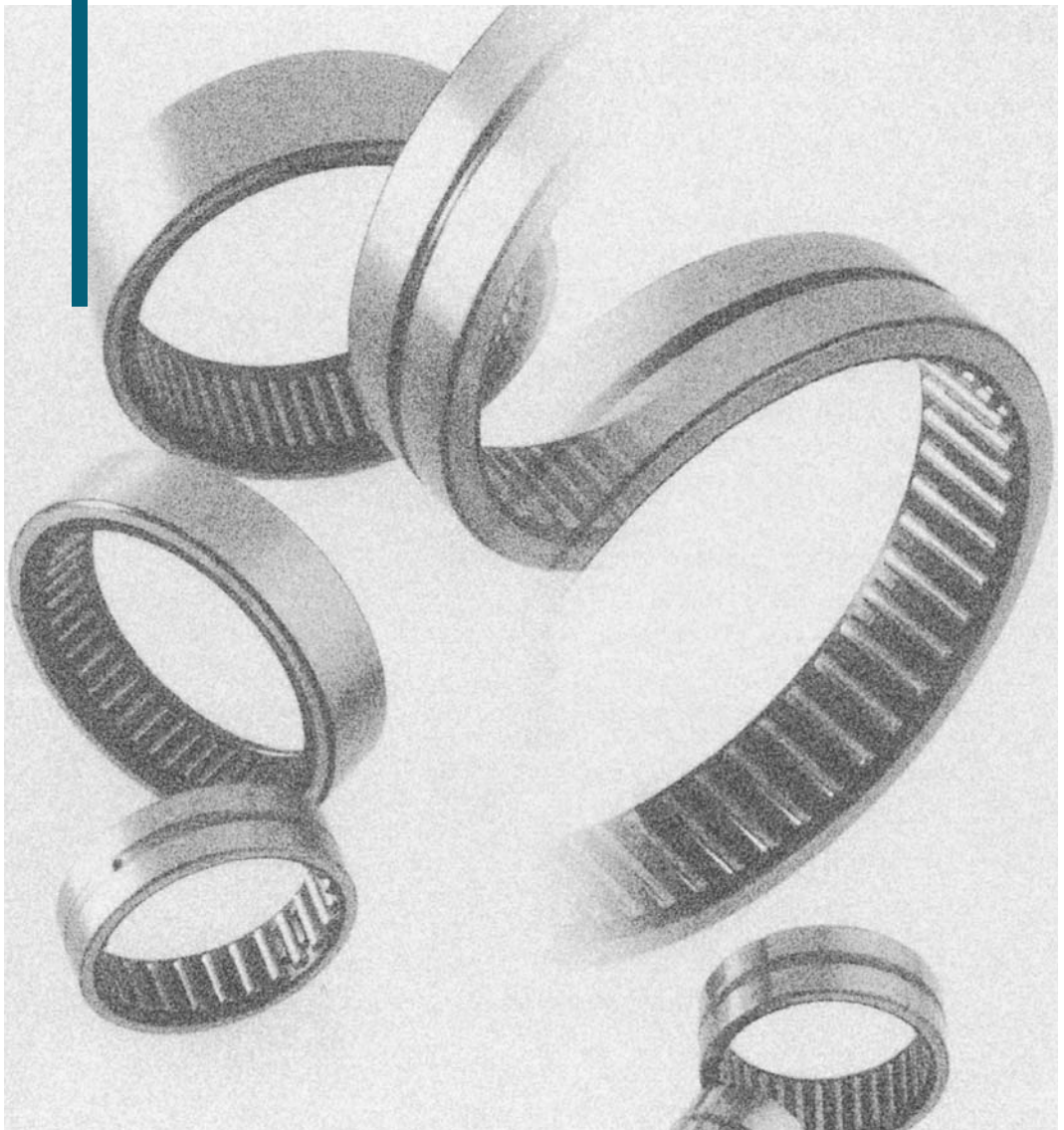

Machined Ring Needle Roller Bearings

The machined ring of this bearing type contains needle rollers and a cage. The outer ring and the needle rollers are inseparable from each other by means of double-side ribs on the outer ring or side plates.

Because of its machined (solid) outer ring enabling to make it more rigid and upgrade the bearing accuracy, this

bearing type is suitable for an application requiring high speed, high load and high running accuracy. These machined ring needle roller bearings are available in two types -- one without inner ring and another with inner ring -- considering the case of using a shaft as the direct raceway surface without using inner ring.

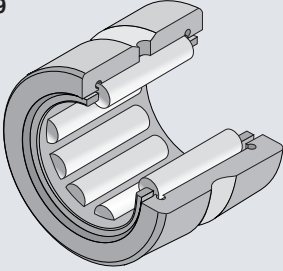
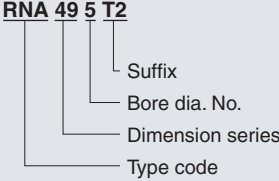
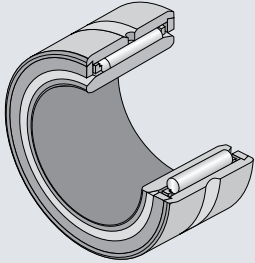
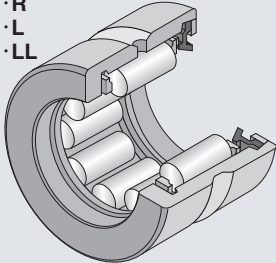
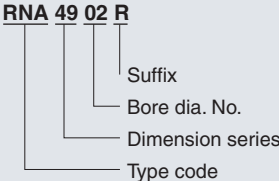
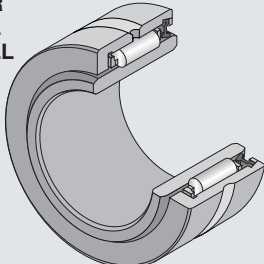
Bearing type	Applicable shaft diameter (mm)	Composition of bearing number	Remarks
Type RNA49 	$\phi 7 - \phi 12$	RNA 49 5 T2 	<p>The bearings with suffix T2 using polyamide resin cage shall be used at allowable temperature 120°C and, under continuous running, at 100°C and less.</p>
Type NA49 	$\phi 5 - \phi 9$	[Suffix] T2: Resin cage	<p>The dimension series is in compliance with JIS B 1512 or ISO 15.</p>
Type RNA49 · R Type RNA49 · L Type RNA49 · LL 	Type RNA49 · R $\phi 14 - \phi 490$ Sealed type Type RNA49 · L Type RNA49 · LL $\phi 14 - \phi 58$	RNA 49 02 R 	<p>Bearing with seal type (Suffix: L or LL) - synthetic rubber seal built in at single side or double sides is internally filled up with lithium soap base grease.</p> <p>To avoid deterioration of seal and grease in a sealed bearing, use a bearing in a temperature range of -20 to 120°C. For continuous machine operation, limit the maximum permissible operating temperature to 100°C.</p>
Type NA49 · R Type NA49 · L Type NA49 · LL 	Type NA49 · R $\phi 10 - \phi 440$ Sealed type Type NA49 · L Type NA49 · LL $\phi 10 - \phi 50$	[Suffix] R: Ribbed type L: Single-side seal type LL: Double-side seal type	<p>The dimension series is in compliance with JIS B 15 or ISO 15.</p>

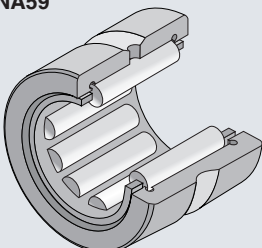
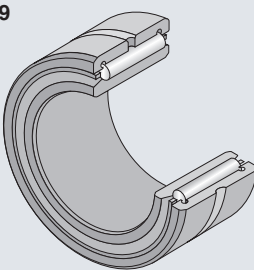
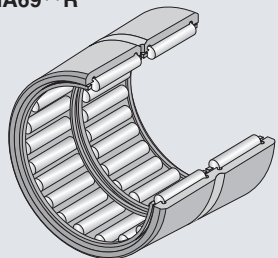
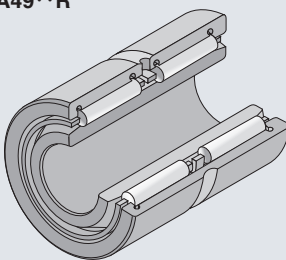
Bearing type	Applicable shaft diameter (mm)	Composition of bearing number	Remarks
Type RNA59 	$\phi 20 - \phi 160$	RNA 59 02 — Bore dia. No. — Dimension series — Type code	The dimension series is in compliance with JIS B 1512 or ISO 15.
Type NA59 	$\phi 15 - \phi 140$	NA 59 / 22 — Dimension code — Dimension series — Type code	
Type RNA69 · R 	$\phi 16 - \phi 35$ Built-in cage single-row type	RNA 69 01 R — Suffix — Bore dia. No. — Dimension series — Type code	
	$\phi 40 - \phi 110$ Built-in cage double-row type		
Type NA49 · R 	$\phi 12 - \phi 30$ Built-in cage single-row type	NA 69 / 22 — Dimension code — Dimension series — Type code	
	$\phi 32 - \phi 95$ Built-in cage double-row type		

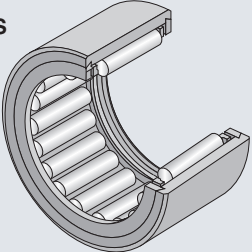
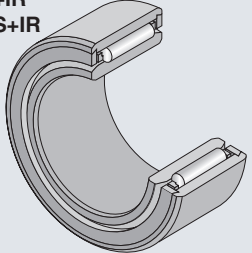
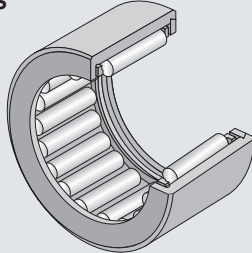
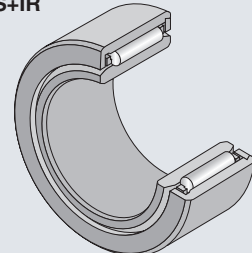
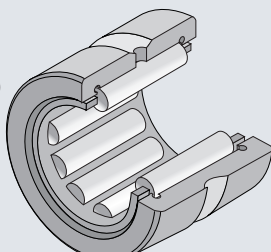
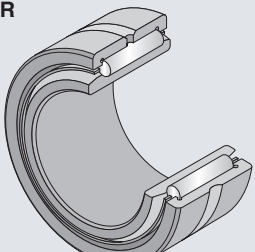
Bearing type	Applicable shaft diameter (mm)	Composition of bearing number	Remarks
Type NK Type NKS 	NK $\phi 5 - \phi 12$ NKS $\phi 8 - \phi 40$	NK 7 / 10 T2 Type code Roller set bore diameter Width Suffix	Bearing with suffix T2 uses a polyamide resin cage and, therefore, it shall be used at allowable temperature 120°C and, under continuous running, at 100°C and lower.
Type NK+IR Type NKS+IR 	NK $\phi 5 - \phi 9$ NKS+IR $\phi 6 - \phi 30$	NKS 16 Type code Roller set bore diameter	
Type NKS 	$\phi 43 - \phi 110$	NK24 / 16R + IR 20 × 24 × 16 Type code Bore diameter Outer diameter Width	
Type NKS+IR 	$\phi 35 - \phi 95$	[Suffix] R: Ribbed type T2: Resin cage	
Type NK · R Type NKS Type MR (Inch series) 	NK · R $\phi 14 - \phi 165$ NKS $\phi 115 - \phi 170$ MR $\phi 15.875 - \phi 234.95$	MR 10 18 12 Type code Roller set bore diameter code Outer diameter code Width code	
Type NK · R+IR Type NKS+IR Type MR+IR (Inch series) 	NK · R+IR $\phi 10 - \phi 150$ NKS+IR $\phi 100 - \phi 150$ MR+MI $\phi 9.525 - \phi 203.2$	MR101812+ MI - 06 10 12 Type code Bore diameter code Outer diameter code Width code	

Bearing Tolerances

The dimensional accuracy, profile accuracy and running accuracy of machined ring needle roller bearings are specified in JIS B 1514 (Accuracy of Rolling Bearings). (Refer to Section 4 "Bearing Tolerances", **Table 4.3** on page A-26.) Although the accuracy of NTN standard bearings conforms to JIS Class-0, NTN can also supply bearings conforming to JIS Class-6, -5 and -4.

The dimensional tolerances for the roller set bore diameter (F_w) of **Types NK, RNA, NKS, and MR** each lacking an inner ring fall in the ISO tolerance class F6.

Feel free to contact NTN for the further detail of these bearings.

For applications that need particularly high running accuracy, certain bearing users install the inner ring onto the shaft and then grind the raceway surface to targeted accuracy. To fulfill this type of request, NTN will supply a special inner ring whose raceway surface includes a grinding allowance. For details, contact NTN Engineering.

Radial internal clearance and bearing fits

NTN machined ring needle roller bearings (with inner ring) are manufactured to the tolerance range of radial internal clearance in **Table 5.1** in Sec. 5.1 "Bearing radial internal clearance" (page A-30). Because of the narrow non-interchangeable clearance range, the bearings shipped after adjusted to a specific non-interchangeable clearance must be installed with the clearance remained unchanged.

The dimensional tolerances (fits) of a shaft and housing bore to which the bearing with inner ring is installed should be in accordance with type and magnitude of load, and dimensions of the shaft and housing bore. For information about the dimensional tolerances of a shaft and housing bore, refer to Sec. 6.4 "Recommended internal fits" (page A-33). For the profile accuracy and surface roughness of the shaft and housing bore corresponding to the recommended internal fits in **Table 8.3** in Sec. 8.3 "Shaft and housing accuracy" (page A-40).

A bearing not having an inner ring directly uses the shaft as raceway surface, and the dimensional tolerances of the shaft diameter (raceway diameter) can vary depending on the operating internal clearance of the bearing as summarized in **Table 1** below. For this type of bearing usage, the dimensional tolerance class for the

Table 1 Shaft diameter (raceway diameter) tolerance (recommended)

Roller inscribed circle dia.		Tolerance range class for shaft		
F_w mm		Smaller than ordinary clearance	Ordinary class	Larger than ordinary clearance
Over	incl.			
	80	k5	h5	f6
80	160	k5	g5	f6
160	180	k5	g5	e6
180	200	j5	g5	e6
200	250	j5	f6	e6
250	315	h5	f6	e6
315	400	g5	f6	d6

housing bore is K7, which is most commonly adopted tolerance class. When wishing to adopt a dimensional tolerance class other than K7 for the housing bore, contact NTN Engineering for technical assistance.

For the profile accuracy, surface roughness and surface hardness of the shaft that functions as raceway surface, refer to Sec. 8.4 "Raceway surface accuracy" (page A-40) and Sec. 8.5 "Material and hardness of raceway" (page A-40).

Oil hole dimension of the outer ring

The outer ring is provided with an oil hole and an oil groove to facilitate oil lubrication to bearing. (However, the description above does not apply to the **Type NK** bearings whose roller set bore diameter (F_w) measures 12 mm or less and the **Type NKS** bearing whose roller set bore diameter (F_w) measures 110 mm or less.)

Table 2 shows the oil hole dimension every outer ring diameter.

Table 2 Oil hole dimension

Outer ring outer diameter Over	incl.	Oil hole dia. (mm)	Number of oil hole
—	20	2.0	1
20	40	2.5	1
40	80	3.0	1
80	200	3.5	1
200	350	4.0	1
350	—	5.0	1

Mounting relations

In the case of raceway with an oil hole, **the bearing must be installed so that the oil hole can locate on the non-load area.** In addition, any bearing with inner ring **must be used within the allowable stroking value (s) (with the rollers retained within the effective contact length range of inner ring).**

For the allowable stroking value (s), refer to **Fig. 1** and applicable "Dimensions Table".

The inner ring and outer ring of machined ring needle roller bearing must be positioned in axial direction by shoulder or snap ring in this case. The mounting relation dimensions about the shaft and housing bore for this case are found in the relevant dimension table.

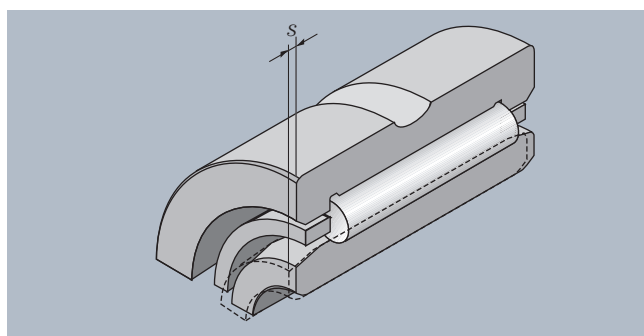
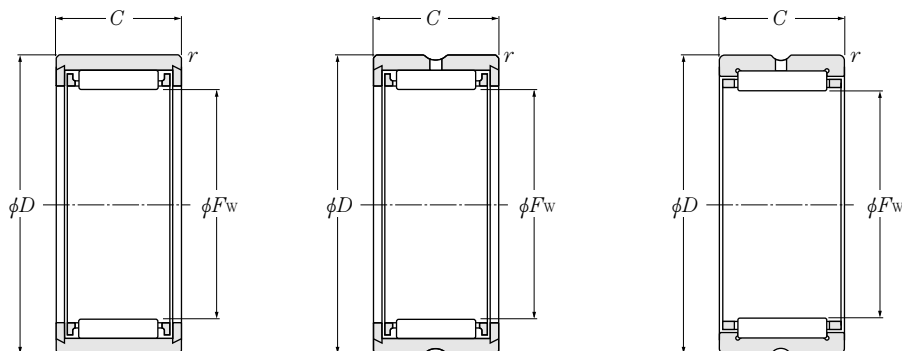

Fig. 1

Without Inner Ring

Type RNA49
Type RNA59
Type RNA69
Type NK
Type NKS



Type NK ($\phi F_w \leq 12\text{mm}$)
Type NKS

Type RNA49 ($\phi F_w \leq 12\text{mm}$)

Type RNA49·R ($\phi F_w \geq 14\text{mm}$)
Type RNA59
Type RNA69·R
Type NK·R ($\phi F_w \geq 14\text{mm}$)

F_w 5~15mm

Boundary dimensions				Basic load ratings				Limiting speeds		Bearing numbers	Abutment dimensions		Mass kg (approx.)
mm				dynamic	static	dynamic	static	min^{-1}			D_a	r_{as}	
F_w	D	C	r_s min ¹⁾	N	N	kgf	kgf	grease	oil		max	max	
5 ^{+0.018 +0.010}	10	10	0.15	2 640	2 190	269	224	27 000	40 000	NK5/10T2	6.5	0.15	0.0031
	10	12	0.15	2 720	2 250	277	230	27 000	40 000	NK5/12T2	6.5	0.15	0.0037
6 ^{+0.018 +0.010}	12	10	0.15	2 660	2 280	272	233	25 000	37 000	NK6/10T2	7.5	0.15	0.0047
	12	12	0.15	3 400	3 150	345	320	25 000	37 000	NK6/12T2	7.5	0.15	0.0057
7 ^{+0.022 +0.013}	13	10	0.15	2 670	2 350	272	239	23 000	34 000	RNA495T2	8.5	0.15	0.0055
	14	10	0.3	2 670	2 350	272	239	23 000	34 000	NK7/10T2	8.5	0.3	0.0069
	14	12	0.3	3 400	3 200	345	330	23 000	34 000	NK7/12T2	8.5	0.3	0.0082
8 ^{+0.022 +0.013}	15	10	0.15	3 150	3 000	320	305	21 000	32 000	RNA496T2T	9.5	0.15	0.0073
	15	12	0.3	4 000	4 100	410	420	21 000	32 000	NK8/12T2	9.5	0.3	0.0087
	15	16	0.3	4 850	5 200	495	535	21 000	32 000	NK8/16	9.5	0.3	0.0120
	16	13	0.3	4 650	4 150	475	425	21 000	32 000	NKS8T2	10	0.3	0.011
9 ^{+0.022 +0.013}	16	12	0.3	4 550	5 000	465	510	20 000	30 000	NK9/12T2	10.5	0.3	0.0100
	16	16	0.3	5 500	6 400	560	650	20 000	30 000	NK9/16T2	10.5	0.3	0.0130
	17	10	0.15	3 600	3 650	365	375	20 000	30 000	RNA497	10.5	0.15	0.0095
10 ^{+0.022 +0.013}	17	12	0.3	4 550	5 100	460	520	19 000	28 000	NK10/12T2	11.5	0.3	0.0100
	17	16	0.3	5 450	6 450	555	660	19 000	28 000	8E-NK10/16CT	11.5	0.3	0.0130
	19	11	0.15	5 250	5 150	535	525	19 000	28 000	RNA498CT	12	0.15	0.0130
	19	13	0.3	5 500	5 450	560	555	19 000	28 000	NKS10	12	0.3	0.015
12 ^{+0.027 +0.016}	19	12	0.3	5 000	6 100	510	620	17 000	26 000	NK12/12	13.5	0.3	0.0130
	19	16	0.3	6 000	7 700	615	785	17 000	26 000	NK12/16	13.5	0.3	0.0160
	20	11	0.3	4 850	4 900	495	500	17 000	26 000	RNA499	14	0.3	0.0130
	22	16	0.3	9 000	9 400	920	960	17 000	26 000	NKS12	14.5	0.3	0.026
14 ^{+0.027 +0.016}	22	13	0.3	8 600	9 200	875	935	16 000	24 000	RNA4900R	20	0.3	0.0170
	22	16	0.3	10 300	11 500	1 050	1 170	16 000	24 000	NK14/16R	20	0.3	0.0210
	22	20	0.3	13 000	15 600	1 330	1 590	16 000	24 000	NK14/20R	20	0.3	0.0260
	25	16	0.3	8 950	9 650	915	985	16 000	24 000	NKS14	16.5	0.3	0.035
15 ^{+0.027 +0.016}	23	16	0.3	10 900	12 700	1 110	1 290	15 000	23 000	NK15/16R	21	0.3	0.0220
	23	20	0.3	13 800	17 200	1 410	1 750	15 000	23 000	NK15/20R	21	0.3	0.0270
	26	16	0.3	10 100	11 500	1 030	1 170	15 000	23 000	NKS15	17.5	0.3	0.028

Note 1) Allowable minimum chamfer dimension r_s .

2) Max. allowable dimension of radius r_a for corner roundness on shaft/housing.

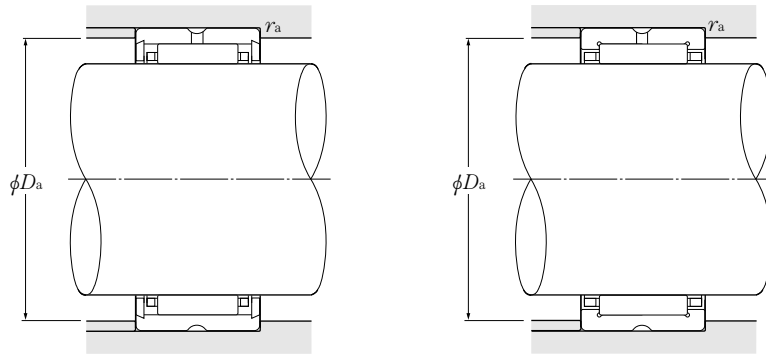

F_w 16~24mm

Boundary dimensions				Basic load ratings				Limiting speeds		Bearing numbers	Abutment dimensions		Mass kg (approx.)
mm				dynamic	static	dynamic	static	min ⁻¹			mm		
F_w	D	C	r_s min ¹⁾	C_r	C_{or}	C_r	C_{or}	grease	oil		D_a max	r_{as} max	
16 ^{+0.027 +0.016}	24	13	0.3	9 550	10 900	975	1 110	15 000	23 000	RNA4901R	22	0.3	0.0170
	24	16	0.3	12 200	14 900	1 240	1 520	15 000	23 000	NK16/16R	22	0.3	0.0220
	24	20	0.3	14 600	18 800	1 490	1 920	15 000	23 000	NK16/20R	22	0.3	0.0280
	24	22	0.3	15 400	20 000	1 570	2 040	15 000	23 000	RNA6901R	22	0.3	0.0310
	28	16	0.3	12 600	13 900	1 290	1 410	15 000	23 000	NKS16	19	0.3	0.039
17 ^{+0.027 +0.016}	25	16	0.3	12 100	15 000	1 240	1 530	15 000	22 000	NK17/16R	23	0.3	0.024
	25	20	0.3	15 400	20 400	1 570	2 080	15 000	22 000	NK17/20R	23	0.3	0.030
18 ^{+0.027 +0.016}	26	16	0.3	12 700	16 200	1 300	1 650	14 000	21 000	NK18/16R	24	0.3	0.025
	26	20	0.3	16 100	22 000	1 640	2 250	14 000	21 000	NK18/20RCT	24	0.3	0.031
	30	16	0.3	11 600	12 800	1 180	1 300	14 000	21 000	NKS18	21	0.3	0.038
19 ^{+0.033 +0.020}	27	16	0.3	13 300	17 400	1 350	1 780	14 000	21 000	NK19/16R	25	0.3	0.026
	27	20	0.3	16 000	22 200	1 630	2 260	14 000	21 000	NK19/20R	25	0.3	0.032
20 ^{+0.033 +0.020}	28	13	0.3	10 300	12 800	1 050	1 310	13 000	20 000	RNA4902R	26	0.3	0.022
	28	16	0.3	13 200	17 500	1 340	1 790	13 000	20 000	NK20/16RCT	26	0.3	0.027
	28	18	0.3	14 100	19 100	1 440	1 950	13 000	20 000	RNA5902CT	26	0.3	0.033
	28	20	0.3	16 700	23 800	1 700	2 420	13 000	20 000	NK20/20R	26	0.3	0.034
	28	23	0.3	17 600	25 300	1 790	2 580	13 000	20 000	RNA6902R	26	0.3	0.040
	32	20	0.3	17 800	22 800	1 810	2 330	13 000	20 000	NKS20	23	0.3	0.049
21 ^{+0.033 +0.020}	29	16	0.3	13 700	18 700	1 400	1 910	13 000	19 000	NK21/16R	27	0.3	0.028
	29	20	0.3	17 400	25 400	1 770	2 590	13 000	19 000	NK21/20R	27	0.3	0.035
22 ^{+0.033 +0.020}	30	16	0.3	14 200	19 900	1 450	2 030	12 000	18 000	NK22/16R	28	0.3	0.034
	30	20	0.3	18 000	27 000	1 840	2 760	12 000	18 000	NK22/20R	28	0.3	0.037
	30	13	0.3	11 200	14 600	1 140	1 490	12 000	18 000	RNA4903R	28	0.3	0.022
	30	18	0.3	15 200	21 700	1 550	2 210	12 000	18 000	RNA5903	28	0.3	0.035
	30	23	0.3	18 200	27 200	1 850	2 770	12 000	18 000	RNA6903R	28	0.3	0.042
	35	20	0.6	17 700	23 300	1 810	2 380	12 000	18 000	NKS22	25	0.6	0.062
24 ^{+0.033 +0.020}	32	16	0.3	15 200	22 300	1 550	2 280	11 000	170 00	NK24/16R	30	0.3	0.032
	32	20	0.3	18 600	28 800	1 890	2 930	11 000	17 000	NK24/20R	30	0.3	0.040
	37	20	0.6	18 400	25 200	1 880	2 570	11 000	17 000	NKS24	27	0.6	0.066

Note 1) Allowable minimum chamfer dimension r .

2) Max. allowable dimension of radius r_a for corner roundness on shaft/housing.

Without Inner Ring

Type RNA49
Type RNA59
Type RNA69
Type NK
Type NKS

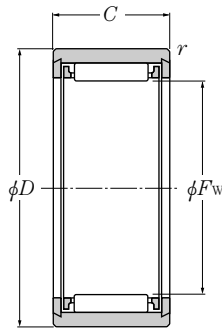

Type NKS
($\phi F_w \leq 40\text{mm}$)

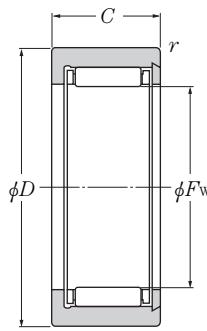

Type NKS
($\phi F_w > 43\text{mm}$)

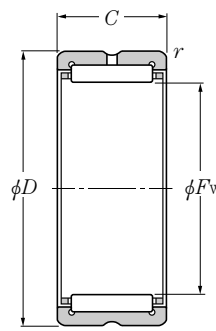

**Type RNA49·R, Type RNA59
Type RNA69·R ($\phi F_w \geq 35\text{mm}$)
Type NK·R**

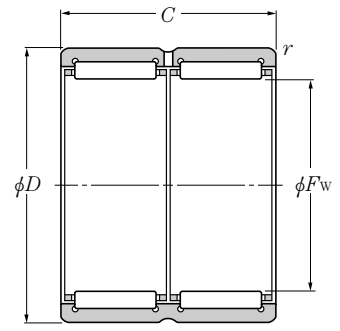

Type RNA69·R
($\phi F_w \geq 40\text{mm}$)

F_w 25~32mm

Boundary dimensions				Basic load ratings				Limiting speeds		Bearing numbers	Abutment dimensions		Mass kg (approx.)
mm				dynamic	static	dynamic	static	grease	oil		D_a max	r_{as} max	
F_w	D	C	r_s min ¹⁾	C_r	C_{or}	C_r	C_{or}			min ⁻¹			
25 ^{+0.033} _{+0.020}	33	16	0.3	15 100	22 400	1 540	2 280	11 000	16 000	NK25/16R	31	0.3	0.033
	33	20	0.3	19 200	30 500	1 960	3 100	11 000	16 000	NK25/20RCT	31	0.3	0.042
	37	17	0.3	21 300	25 500	2 170	2 600	11 000	16 000	RNA4904RCT	35	0.3	0.052
	37	23	0.3	28 400	37 000	2 900	3 750	11 000	16 000	RNA5904	35	0.3	0.084
	37	30	0.3	36 500	50 500	3 700	5 150	11 000	16 000	RNA6904R	35	0.3	0.100
	38	20	0.6	18 300	25 300	1 870	2 580	11 000	16 000	NKS25	28	0.6	0.068
26 ^{+0.033} _{+0.020}	34	16	0.3	15 600	23 600	1 590	2 410	10 000	15 000	NK26/16R	32	0.3	0.034
	34	20	0.3	19 100	30 500	1 940	3 100	10 000	15 000	NK26/20R	32	0.3	0.042
28 ^{+0.033} _{+0.020}	37	20	0.3	22 300	34 000	2 280	3 450	9 500	14 000	NK28/20R	35	0.3	0.052
	37	30	0.3	26 700	48 000	2 720	4 900	9 500	14 000	NK28/30RCT	35	0.3	0.082
	39	17	0.3	23 200	29 300	2 360	2 990	9 500	14 000	RNA49/22R	37	0.3	0.050
	39	23	0.3	26 400	37 500	2 690	3 850	9 500	14 000	RNA59/22	37	0.3	0.092
	39	30	0.3	40 000	58 500	4 050	6 000	9 500	14 000	RNA69/22R	37	0.3	0.100
	42	20	0.6	18 100	25 800	1 850	2 630	9 500	14 000	NKS28	31	0.6	0.084
29 ^{+0.033} _{+0.020}	38	20	0.3	22 200	34 000	2 270	3 450	9 500	14 000	NK29/20R	36	0.3	0.054
	38	30	0.3	27 500	50 500	2 810	5 150	9 500	14 000	NK29/30R	36	0.3	0.084
30 ^{+0.033} _{+0.020}	40	20	0.3	22 100	34 000	2 260	3 500	8 500	13 000	NK30/20R	38	0.3	0.065
	40	30	0.3	33 000	57 000	3 350	5 800	8 500	13 000	NK30/30R	38	0.3	0.098
	42	17	0.3	24 000	31 500	2 450	3 200	8 500	13 000	RNA4905R	40	0.3	0.061
	42	23	0.3	30 500	43 000	3 150	4 350	8 500	13 000	RNA5905	40	0.3	0.101
	42	30	0.3	41 500	63 000	4 200	6 400	8 500	13 000	RNA6905R	40	0.3	0.112
	45	22	0.6	23 300	33 000	2 370	3 350	8 500	13 000	NKS30	33.5	0.6	0.104
32 ^{+0.041} _{+0.025}	42	20	0.3	23 500	37 500	2 400	3 850	8 500	13 000	NK32/20R	40	0.3	0.068
	42	30	0.3	34 000	60 500	3 450	6 150	8 500	13 000	NK32/30R	40	0.3	0.102
	45	17	0.3	24 800	33 500	2 530	3 400	8 500	13 000	RNA49/28RCT	43	0.3	0.073
	45	23	0.3	32 000	45 500	3 250	4 650	8 500	13 000	RNA59/28	43	0.3	0.108
	45	30	0.3	43 000	67 000	4 350	6 850	8 500	13 000	RNA69/28R	43	0.3	0.135
	47	22	0.6	24 000	35 000	2 450	3 550	8 500	13 000	NKS32	35.5	0.6	0.11

Note 1) Allowable minimum chamfer dimension r_s .

2) Max. allowable dimension of radius r_a for corner roundness on shaft/housing.

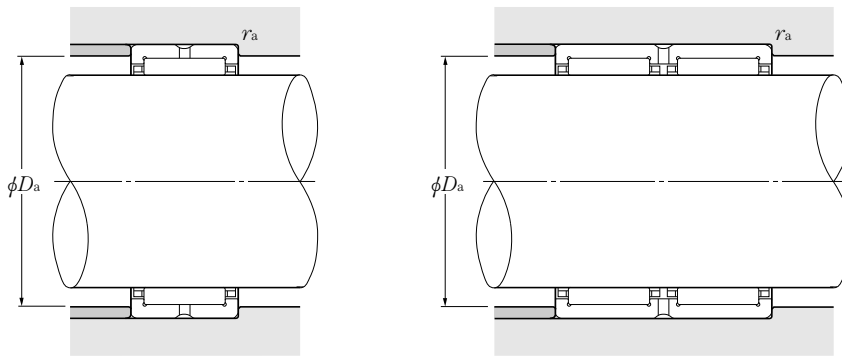

F_w 35~45mm

Boundary dimensions				Basic load ratings				Limiting speeds		Bearing numbers	Abutment dimensions		Mass kg (approx.)
mm				dynamic	static	dynamic	static	min ⁻¹			mm		
F_w	D	C	r_s min ¹⁾	C_r	C_{or}	C_r	C_{or}	grease	oil		D_a max	r_{as} max	
35 ^{+0.041} _{+0.025}	45	20	0.3	24 800	41 500	2 520	4 250	7 500	11 000	NK35/20RCT	43	0.3	0.074
	45	30	0.3	36 000	66 500	3 650	6 800	7 500	11 000	NK35/30R	43	0.3	0.112
	47	17	0.3	25 500	35 500	2 600	3 600	7 500	11 000	RNA4906R	45	0.3	0.069
	47	23	0.3	32 500	48 500	3 350	4 950	7 500	11 000	RNA5906	45	0.3	0.108
	47	30	0.3	42 500	67 500	4 300	6 900	7 500	11 000	RNA6906R	45	0.3	0.126
	50	22	0.6	24 700	37 000	2 510	3 750	7 500	11 000	NKS35	38.5	0.6	0.118
37 ^{+0.041} _{+0.025}	47	20	0.3	25 300	43 500	2 580	4 400	7 500	11 000	NK37/20R	45	0.3	0.077
	47	30	0.3	36 500	69 500	3 750	7 100	7 500	11 000	NK37/30R	45	0.3	0.107
	52	22	0.6	26 300	41 000	2 680	4 150	7 500	11 000	NKS37	40.5	0.6	0.123
38 ^{+0.041} _{+0.025}	48	20	0.3	25 900	45 000	2 640	4 600	7 500	11 000	NK38/20R	46	0.3	0.079
	48	30	0.3	37 500	73 000	3 850	7 400	7 500	11 000	NK38/30R	46	0.3	0.107
40 ^{+0.041} _{+0.025}	50	20	0.3	26 400	47 000	2 700	4 800	6 500	10 000	NK40/20R	48	0.3	0.083
	50	30	0.3	38 500	76 000	3 900	7 750	6 500	10 000	NK40/30R	48	0.3	0.125
	52	20	0.6	31 500	47 500	3 200	4 850	6 500	10 000	RNA49/32R	48	0.6	0.089
	52	27	0.6	38 000	61 000	3 850	6 250	6 500	10 000	RNA59/32	48	0.6	0.149
	52	36	0.6	47 500	82 000	4 850	8 350	6 500	10 000	RNA69/32R	48	0.6	0.162
	55	22	0.6	27 700	45 000	2 820	4 550	6 500	10000	NKS40	43.5	0.6	0.129
42 ^{+0.041} _{+0.025}	52	20	0.3	26 900	49 000	2 750	5 000	6 500	9 500	NK42/20R	50	0.3	0.086
	52	30	0.3	39 000	79 000	4 000	8 050	6 500	9 500	NK42/30R	50	0.3	0.130
	55	20	0.6	32 000	50 000	3 300	5 100	6 500	9 500	RNA4907R	51	0.6	0.107
	55	27	0.6	39 000	64 500	3 950	6 550	6 500	9 500	RNA5907	51	0.6	0.176
	55	36	0.6	49 000	86 500	5 000	8 800	6 500	9 500	RNA6907R	51	0.6	0.193
43 ^{+0.041} _{+0.025}	53	20	0.3	27 500	51 000	2 810	5 200	6 500	9 500	NK43/20R	51	0.3	0.086
	53	30	0.3	40 000	82 000	4 100	8 400	6 500	9 500	NK43/30R	51	0.3	0.133
	58	22	0.6	29 100	49 000	2 960	5 000	6 500	9 500	NKS43	46.5	0.6	0.14
45 ^{+0.041} _{+0.025}	55	20	0.3	28 000	52 500	2 860	5 400	6 000	9 000	NK45/20R	53	0.3	0.092
	55	30	0.3	41 000	85 500	4 150	8 700	6 000	9 000	NK45/30RCT	53	0.3	0.139
	60	22	0.6	29 700	51 000	3 000	5 200	6 000	9 000	NKS45	48.5	0.6	0.16

Note 1) Allowable minimum chamfer dimension r .

2) Max. allowable dimension of radius r_a for corner roundness on shaft/housing.

Without Inner Ring

Type RNA49
Type RNA59
Type RNA69
Type NK
Type NKS

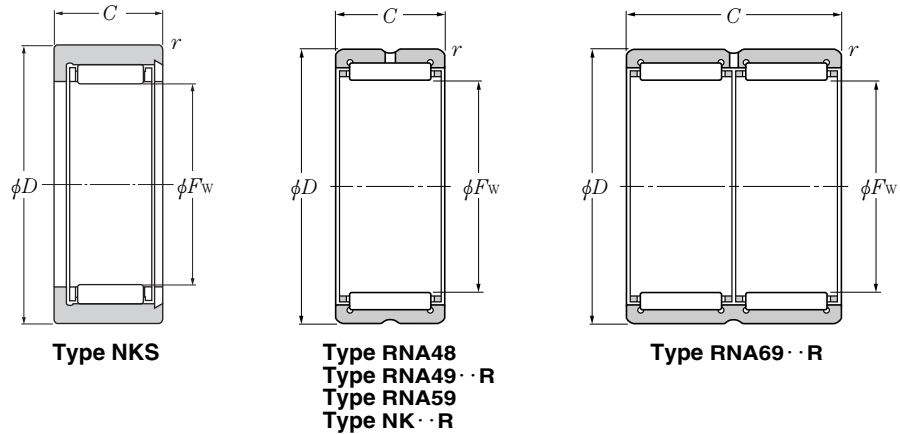

F_w 47~68mm

Boundary dimensions	Basic load ratings			Limiting speeds		Bearing numbers	Abutment dimensions		Mass				
	mm			dynamic	static		min ⁻¹			mm			
	F_w	D	C	N	kgf		grease	oil		D_a max	r_{as} max		
47 ^{+0.041} / _{+0.025}	57	20	0.3	28 800	55 500	2 940	5 650	5 500	8 500	NK47/20RCT	55	0.3	0.095
	57	30	0.3	42 500	91 500	4 350	9 350	5 500	8 500	NK47/30R	55	0.3	0.142
48 ^{+0.041} / _{+0.025}	62	22	0.6	43 500	66 500	4 450	6 800	5 500	8 500	RNA4908R	58	0.6	0.140
	62	30	0.6	53 000	92 500	5 450	9 450	5 500	8 500	RNA5908	58	0.6	0.225
	62	40	0.6	67 000	116 000	6 850	11 800	5 500	8 500	RNA6908R	58	0.6	0.256
50 ^{+0.041} / _{+0.025}	62	25	0.6	38 500	74 500	3 950	7 550	5 500	8 000	NK50/25RCT	58	0.6	0.158
	62	35	0.6	51 000	106 000	5 200	10 800	5 500	8 000	NK50/35R	58	0.6	0.221
	65	22	1	31 500	57 000	3 200	5 800	5 500	8 000	NKS50	53.5	1	0.157
52 ^{+0.049} / _{+0.030}	68	22	0.6	46 000	73 000	4 700	7 450	5 000	7 500	RNA4909R	64	0.6	0.182
	68	30	0.6	56 000	101 000	5 700	10 300	5 000	7 500	RNA5909	64	0.6	0.232
	68	40	0.6	70 500	127 000	7 200	13 000	5 000	7 500	RNA6909R	64	0.6	0.273
55 ^{+0.049} / _{+0.030}	68	25	0.6	41 000	82 000	4 150	8 400	5 000	7 500	NK55/25R	64	0.6	0.193
	68	35	0.6	54 000	118 000	5 500	12 000	5 000	7 500	NK55/35R	64	0.6	0.26
	72	22	1	33 500	63 000	3 400	6 450	5 000	7 500	NKS55	58.5	1	0.221
58 ^{+0.049} / _{+0.030}	72	22	0.6	48 000	80 000	4 900	8 150	4 700	7 000	RNA4910R	68	0.6	0.163
	72	30	0.6	58 000	110 000	5 950	11 200	4 700	7 000	RNA5910	68	0.6	0.289
	72	40	0.6	74 000	139 000	7 500	14 200	4 700	7 000	RNA6910R	68	0.6	0.320
60 ^{+0.049} / _{+0.030}	72	25	0.6	41 000	85 000	4 200	8 700	4 300	6 500	NK60/25R	68	0.6	0.185
	72	35	0.6	57 000	130 000	5 800	13 200	4 300	6 500	NK60/35R	68	0.6	0.258
	80	28	1.1	44 500	85 000	4 500	8 700	4 300	6 500	NKS60	64	1.1	0.335
63 ^{+0.049} / _{+0.030}	80	25	1	58 500	99 500	6 000	10 100	4 300	6 500	RNA4911R	75	1	0.255
	80	34	1	76 500	140 000	7 800	14 300	4 300	6 500	RNA5911	75	1	0.367
	80	45	1	94 000	183 000	9 600	18 600	4 300	6 500	RNA6911R	75	1	0.470
65 ^{+0.049} / _{+0.030}	78	25	0.6	45 000	98 000	4 550	10 000	4 000	6 000	NK65/25R	74	0.6	0.221
	78	35	0.6	60 000	142 000	6 100	14 400	4 000	6 000	NK65/35R	74	0.6	0.310
	85	28	1.1	47 000	94 000	4 800	9 600	4 000	6 000	NKS65	69	1.1	0.356
68 ^{+0.049} / _{+0.030}	82	25	1	44 500	89 000	4 500	9 050	4 000	6 000	NK68/25R	77	0.6	0.241
	82	35	0.6	63 000	139 000	6 400	14 200	4 000	6 000	NK68/35R	78	0.6	0.338
	85	25	1	61 500	108 000	6 250	11 000	4 000	6 000	RNA4912R	80	1	0.275

Note 1) Allowable minimum chamfer dimension r .

2) Max. allowable dimension of radius r_a for corner roundness on shaft/housing.

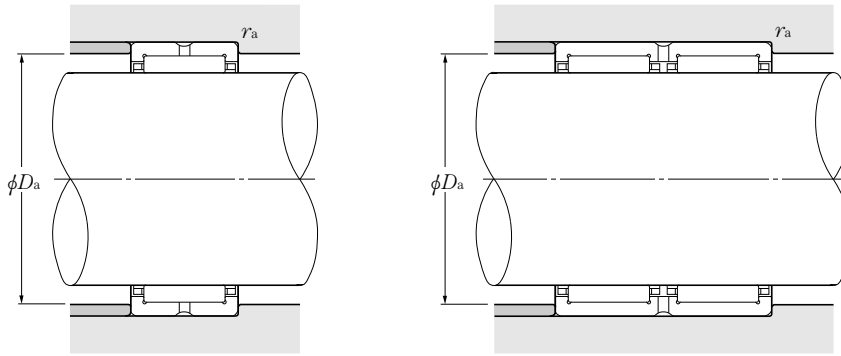

F_w 68~90mm

Boundary dimensions				Basic load ratings				Limiting speeds		Bearing numbers	Abutment dimensions		Mass kg (approx.)
mm				dynamic	static	dynamic	static	min ⁻¹			mm		
F_w	D	C	r_s min ¹⁾	C_r	C_{or}	C_r	C_{or}	grease	oil		D_a max	r_{as} max	
68 ^{+0.049} _{+0.030}	85	34	1	80 500	153 000	8 200	15 600	4 000	6 000	RNA5912	80	1	0.408
	85	45	1	95 500	191 000	9 750	19 400	4 000	6 000	RNA6912R	80	1	0.488
70 ^{+0.049} _{+0.030}	85	25	0.6	45 000	91 500	4 600	9 350	3 700	5 500	NK70/25R	81	0.6	0.275
	85	35	0.6	64 000	144 000	6 550	14 700	3 700	5 500	NK70/35R	81	0.6	0.386
	90	28	1.1	49 500	103 000	5 050	10 500	3 700	5 500	NKS70	74	1.1	0.38
72 ^{+0.049} _{+0.030}	90	25	1	62 500	112 000	6 350	11 400	3 700	5 500	RNA4913R	85	1	0.312
	90	34	1	84 000	165 000	8 600	16 800	3 700	5 500	RNA5913	85	1	0.462
	90	45	1	97 000	198 000	9 900	20 200	3 700	5 500	RNA6913R	85	1	0.520
73 ^{+0.049} _{+0.030}	90	25	0.6	54 000	100 000	5 500	10 200	3 700	5 500	NK73/25R	86	0.6	0.302
	90	35	0.6	76 500	156 000	7 800	16 000	3 700	5 500	NK73/35R	86	0.6	0.428
75 ^{+0.049} _{+0.030}	92	25	0.6	55 000	104 000	5 600	10 600	3 700	5 500	NK75/25R	88	0.6	0.315
	92	35	0.6	78 000	162 000	7 950	16 500	3 700	5 500	NK75/35R	88	0.6	0.492
	95	28	1.1	50 500	109 000	5 150	11 100	3 700	5 500	NKS75	79	1.1	0.402
80 ^{+0.049} _{+0.030}	95	25	1	57 000	119 000	5 800	12 200	3 300	5 000	NK80/25R	90	1	0.301
	95	35	1	79 500	184 000	8 150	18 700	3 300	5 000	NK80/35R	90	1	0.425
	100	28	1.1	53 000	118 000	5 400	12 100	3 300	5 000	NKS80	84	1.1	0.413
	100	30	1	85 500	156 000	8 750	15 900	3 300	5 000	RNA4914R	95	1	0.460
	100	40	1	103 000	187 000	10 500	19 100	3 300	5 000	RNA5914	95	1	0.706
85 ^{+0.058} _{+0.036}	100	54	1	130 000	267 000	13 300	27 200	3 300	5 000	RNA6914R	95	1	0.857
	105	25	1	70 500	123 000	7 200	12 600	3 100	4 700	NK85/25R	100	1	0.404
	105	30	1	87 000	162 000	8 900	16 500	3 100	4 700	RNA4915R	100	1	0.489
	105	32	1.1	64 000	153 000	6 500	15 600	3 100	4 700	NKS85	89	1.1	0.475
	105	35	1	100 000	193 000	10 200	19 700	3 100	4 700	NK85/35R	100	1	0.517
	105	40	1	109 000	205 000	11 100	20 900	3 100	4 700	RNA5915	100	1	0.745
90 ^{+0.058} _{+0.036}	105	54	1	132 000	277 000	13 500	28 300	3 100	4 700	RNA6915R	100	1	0.935
	110	25	1	71 500	128 000	7 300	13 100	2 900	4 400	NK90/25R	105	1	0.426
	110	30	1	90 500	174 000	9 250	17 700	2 900	4 400	RNA4916R	105	1	0.516
	110	32	1.1	64 000	157 000	6 550	16 000	2 900	4 400	NKS90	94	1.1	0.714
	110	35	1	104 000	208 000	10 600	21 200	2 900	4 400	NK90/35R	105	1	0.604

Note 1) Allowable minimum chamfer dimension r_s .

2) Max. allowable dimension of radius r_a for corner roundness on shaft/housing.

Without Inner Ring

Type RNA49
 Type RNA59
 Type RNA69
 Type NK
 Type NKS

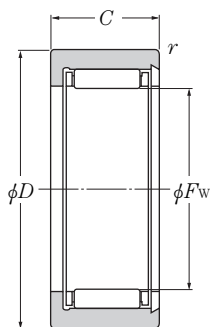

Type NKS
 ($\phi F_w \leq 110\text{mm}$)

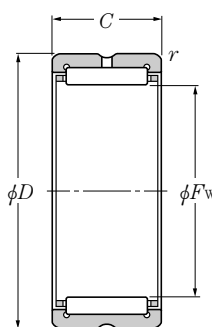

Type RNA48
Type RNA49·R, Type RNA49
Type RNA59
Type NK·R, Type NK
Type NKS ($\phi F_w \geq 115\text{mm}$)

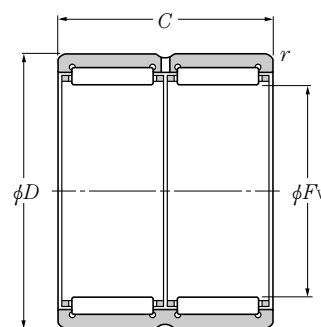

Type RNA69·R

F_w 90~125mm

Boundary dimensions				Basic load ratings				Limiting speeds		Bearing numbers	Abutment dimensions		Mass kg (approx.)
mm				dynamic	static	dynamic	static	grease	oil		D_a max	r_{as} max	
F_w	D	C	r_s min ¹⁾	N	N	kgf	kgf			min ⁻¹			
90 ^{+0.058} _{+0.036}	110	40	1	115 000	223 000	11 700	22 700	2 900	4 400	RNA5916	105	1	0.787
	110	54	1	138 000	298 000	14 000	30 500	2 900	4 400	RNA6916R	105	1	0.987
95 ^{+0.058} _{+0.036}	115	26	1	74 500	137 000	7 600	14 000	2 800	4 200	NK95/26R	110	1	0.364
	115	32	1.1	65 500	165 000	6 700	16 800	2 800	4 200	NKS95	99	1.1	0.765
	115	36	1	108 000	223 000	11 100	22 700	2 800	4 200	NK95/36R	110	1	0.652
100 ^{+0.058} _{+0.036}	120	26	1	73 500	137 000	7 500	14 000	2 700	4 000	NK100/26R	115	1	0.487
	120	32	1.1	61 000	153 000	6 250	15 600	2 700	4 000	NKS100	104	1.1	0.67
	120	35	1.1	112 000	237 000	11 500	24 200	2 700	4 000	RNA4917R	113.5	1	0.657
	120	36	1	107 000	223 000	11 000	22 800	2 700	4 000	NK100/36R	115	1	0.679
	120	46	1.1	137 000	290 000	14 000	29 600	2 700	4 000	RNA5917	113.5	1	1.00
	120	63	1.1	169 000	400 000	17 300	41 000	2 700	4 000	RNA6917R	113.5	1	1.20
105 ^{+0.058} _{+0.036}	125	26	1	76 500	147 000	7 800	14 900	2 500	3 800	NK105/26R	120	1	0.506
	125	32	1.1	67 500	176 000	6 850	18 000	2 500	3 800	NKS105	109	1.1	0.68
	125	35	1.1	116 000	252 000	11 900	25 700	2 500	3 800	RNA4918R	118.5	1	0.697
	125	36	1	111 000	238 000	11 400	24 300	2 500	3 800	NK105/36R	120	1	0.713
	125	46	1.1	143 000	310 000	14 600	32 000	2 500	3 800	RNA5918	118.5	1	1.04
	125	63	1.1	175 000	425 000	17 900	43 500	2 500	3 800	RNA6918R	118.5	1	1.33
110 ^{+0.058} _{+0.036}	130	30	1.1	97 500	204 000	9 950	20 800	2 400	3 600	NK110/30R	123.5	1	0.612
	130	32	1.1	64 500	170 000	6 600	17 300	2 400	3 600	NKS110	114	1.1	0.695
	130	35	1.1	118 000	260 000	12 000	26 500	2 400	3 600	RNA4919R	123.5	1	0.719
	130	40	1.1	129 000	292 000	13 100	29 700	2 400	3 600	NK110/40R	123.5	1	0.830
	130	46	1.1	149 000	335 000	15 200	34 000	2 400	3 600	RNA5919	123.5	1	1.13
	130	63	1.1	177 000	440 000	18 100	45 000	2 400	3 600	RNA6919R	123.5	1	1.46
115 ^{+0.058} _{+0.036}	135	32	1.1	90 500	199 000	9 250	20 300	2 300	3 500	NKS115	128.5	1.1	0.7
	140	40	1.1	127 000	260 000	12 900	26 500	2 300	3 500	RNA4920	133.5	1	1.15
	140	54	1.1	182 000	395 000	18 600	40 500	2 300	3 500	RNA5920	133.5	1	1.76
120 ^{+0.058} _{+0.036}	140	30	1	93 500	210 000	9 550	21 400	2 200	3 300	RNA4822	135	1	0.670
	140	40	1.1	113 000	268 000	11 500	27 300	2 200	3 300	NK120/40	133.5	1	0.910
125 ^{+0.068} _{+0.043}	150	40	1.1	131 000	279 000	13 300	28 400	2 100	3 200	RNA4922	143.5	1	1.24

Note 1) Allowable minimum chamfer dimension r .

2) Max. allowable dimension of radius r_a for corner roundness on shaft/housing.

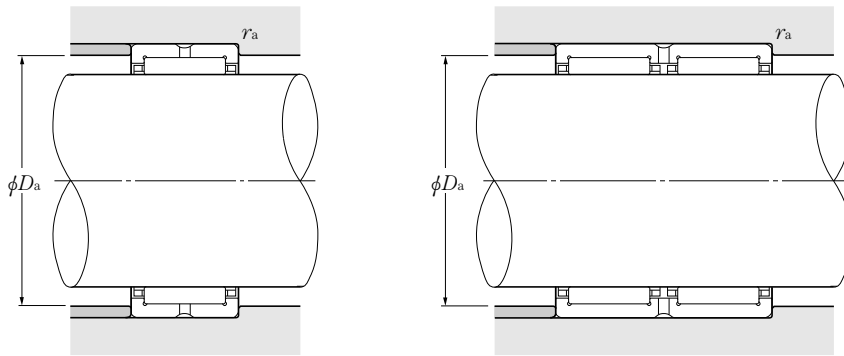

F_w 125~190mm

Boundary dimensions				Basic load ratings				Limiting speeds		Bearing numbers	Abutment dimensions		Mass kg (approx.)
mm				dynamic	static	dynamic	static	min ⁻¹			D _a max	r _{as} max	
F _w	D	C	r _s min ¹⁾	C _r	C _{or}	C _r	C _{or}	grease	oil				
125 ^{+0.068} / _{+0.043}	150	54	1.1	193 000	440 000	19 700	45 000	2 100	3 200	RNA5922	143.5	1	1.89
130 ^{+0.068} / _{+0.043}	150	30	1	99 500	233 000	10 100	23 800	2 100	3 100	RNA4824	145	1	0.730
	150	40	1.1	116 000	283 000	11 800	28 800	2 100	3 100	NK130/40	143.5	1	0.98
135 ^{+0.068} / _{+0.043}	160	40	2	135 000	298 000	13 800	30 500	2 000	3 000	NKS135	151	2	1.32
	165	45	1.1	180 000	380 000	18 300	38 500	2 000	3 000	RNA4924	158.5	1	1.86
	165	60	1.1	246 000	530 000	25 100	54 000	2 000	3 000	RNA5924	158.5	1	2.67
145 ^{+0.068} / _{+0.043}	165	35	1.1	118 000	305 000	12 100	31 000	1 900	2 800	RNA4826	158.5	1	0.95
	170	32	1.5	111 000	238 000	11 300	24 300	1 900	2 800	NK145/32	162.5	1.5	1.12
	170	42	1.5	153 000	360 000	15 600	36 500	1 900	2 800	NK145/42	162.5	1.5	1.49
150 ^{+0.068} / _{+0.043}	180	50	1.5	202 000	455 000	20 600	46 500	1 800	2 700	RNA4926	172	1.5	2.21
	180	52	2	202 000	455 000	20 600	46 500	1 800	2 700	NKS150	171	2	2.32
	180	67	1.5	296 000	690 000	30 000	70 500	1 800	2 700	RNA5926	172	1.5	3.21
155 ^{+0.068} / _{+0.043}	175	35	1.1	121 000	315 000	12 300	32 500	1 700	2 600	RNA4828	168.5	1	1.02
	180	32	1.5	114 000	252 000	11 600	25 700	1 700	2 600	NK155/32	172	1.5	1.20
	180	42	1.5	156 000	380 000	16 000	38 500	1 700	2 600	NK155/42	172	1.5	1.59
160 ^{+0.068} / _{+0.043}	190	50	1.5	209 000	485 000	21 300	49 500	1 700	2 500	RNA4928	182	1.5	2.35
	190	52	2	209 000	485 000	21 300	49 500	1 700	2 500	NKS160	181	2	2.45
	190	67	1.5	315 000	760 000	32 000	77 500	1 700	2 500	RNA5928	182	1.5	3.48
165 ^{+0.068} / _{+0.043}	190	32	1.5	117 000	265 000	11 900	27 000	1 600	2 400	NK165/32	182	1.5	1.42
	190	40	1.1	152 000	390 000	15 500	40 000	1 600	2 400	RNA4830	183.5	1	1.60
	190	42	1.5	160 000	400 000	16 300	40 500	1 600	2 400	NK165/42	182	1.5	1.66
170 ^{+0.068} / _{+0.043}	200	52	2	215 000	515 000	21 900	52 500	1 600	2 400	NKS170	191	2	2.59
	210	60	2	261 000	610 000	26 600	62 500	1 600	2 400	RNA4930	201	2	2.98
175 ^{+0.068} / _{+0.043}	200	40	1.1	160 000	425 000	16 300	43 500	1 500	2 300	RNA4832	193.5	1	1.70
180 ^{+0.068} / _{+0.043}	220	60	2	270 000	650 000	27 600	66 500	1 500	2 200	RNA4932	211	2	3.10
185 ^{+0.079} / _{+0.050}	215	45	1.1	185 000	495 000	18 800	50 500	1 500	2 200	RNA4834	208.5	1	2.54
190 ^{+0.079} / _{+0.050}	230	60	2	279 000	690 000	28 500	70 500	1 400	2 100	RNA4934	221	2	3.22

Note 1) Allowable minimum chamfer dimension r_s.

2) Max. allowable dimension of radius r_a for corner roundness on shaft/housing.

Without Inner Ring

Type RNA48

Type RNA49

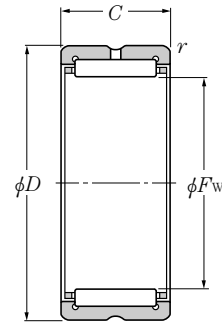

F_w 195~450mm

Boundary dimensions				Basic load ratings				Limiting speeds		Bearing numbers	Abutment dimensions		Mass kg (approx.)
mm				dynamic	static	dynamic	static	min ⁻¹			D_a	r_{as}	
F_w	D	C	r_s min ¹⁾	N		kgf		grease	oil	max	max		
				C_r	C_{or}	C_r	C_{or}						
195 ^{+0.079} / _{+0.050}	225	45	1.1	195 000	540 000	19 800	55 000	1 400	2 100	RNA4836	218.5	1	2.68
205 ^{+0.079} / _{+0.050}	250	69	2	375 000	890 000	38 500	90 500	1 300	2 000	RNA4936	241	2	4.48
210 ^{+0.079} / _{+0.050}	240	50	1.5	227 000	680 000	23 200	69 000	1 300	1 900	RNA4838	232	1.5	3.21
215 ^{+0.079} / _{+0.050}	260	69	2	390 000	945 000	40 000	96 500	1 300	1 900	RNA4938	251	2	4.53
220 ^{+0.079} / _{+0.050}	250	50	1.5	231 000	705 000	23 600	71 500	1 200	1 800	RNA4840	242	1.5	3.35
225 ^{+0.079} / _{+0.050}	280	80	2.1	505 000	1 180 000	51 500	120 000	1 200	1 800	RNA4940	269	2	7.20
240 ^{+0.079} / _{+0.050}	270	50	1.5	244 000	780 000	24 900	79 500	1 100	1 700	RNA4844	262	1.5	3.62
245 ^{+0.079} / _{+0.050}	300	80	2.1	525 000	1 270 000	53 500	129 000	1 100	1 600	RNA4944	289	2	7.81
265 ^{+0.088} / _{+0.056}	300	60	2	360 000	1 080 000	37 000	110 000	1 000	1 500	RNA4848	291	2	5.40
	320	80	2.1	540 000	1 350 000	55 000	138 000	1 000	1 500	RNA4948	309	2	8.40
285 ^{+0.088} / _{+0.056}	320	60	2	375 000	1 160 000	38 000	119 000	950	1 400	RNA4852	311	2	5.80
290 ^{+0.088} / _{+0.056}	360	100	2.1	805 000	1 900 000	82 000	193 000	950	1 400	RNA4952	349	2	15.90
305 ^{+0.088} / _{+0.056}	350	69	2	455 000	1 300 000	46 500	133 000	850	1 300	RNA4856	341	2	9.30
310 ^{+0.088} / _{+0.056}	380	100	2.1	835 000	2 030 000	85 000	207 000	850	1 300	RNA4956	369	2	16.70
330 ^{+0.098} / _{+0.062}	380	80	2.1	625 000	1 770 000	64 000	180 000	800	1 200	RNA4860	369	2	12.70
340 ^{+0.098} / _{+0.062}	420	118	3	1 080 000	2 640 000	110 000	269 000	800	1 200	RNA4960	407	2.5	24.00
350 ^{+0.098} / _{+0.062}	400	80	2.1	640 000	1 850 000	65 500	189 000	750	1 100	RNA4864	389	2	13.40
360 ^{+0.098} / _{+0.062}	440	118	3	1 120 000	2 820 000	114 000	288 000	750	1 100	RNA4964	427	2.5	25.20
370 ^{+0.098} / _{+0.062}	420	80	2.1	655 000	1 940 000	66 500	197 000	750	1 100	RNA4868	409	2	14.00
380 ^{+0.098} / _{+0.062}	460	118	3	1 160 000	3 000 000	118 000	305 000	750	1 100	RNA4968	447	2.5	26.50
390 ^{+0.098} / _{+0.062}	440	80	2.1	665 000	2 020 000	68 000	206 000	650	1 000	RNA4872	429	2	14.80
400 ^{+0.108} / _{+0.068}	480	118	3	1 200 000	3 200 000	122 000	325 000	650	1 000	RNA4972	467	2.5	28.20
415 ^{+0.108} / _{+0.068}	480	100	2.1	1 000 000	2 840 000	102 000	289 000	650	950	RNA4876	469	2	26.00
430 ^{+0.108} / _{+0.068}	520	140	4	1 400 000	3 750 000	143 000	385 000	650	950	RNA4976	504	3	38.60
450 ^{+0.108} / _{+0.068}	540	140	4	1 450 000	4 000 000	148 000	410 000	600	900	RNA4980	524	3	40.10

Note 1) Allowable minimum chamfer dimension r .

2) Max. allowable dimension of radius r_a for corner roundness on shaft/housing.

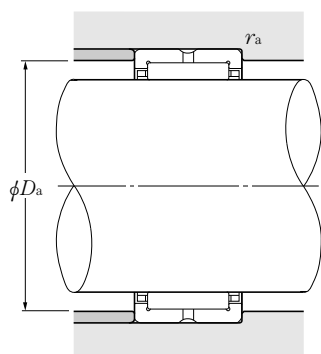

F_w 470~490mm

Boundary dimensions				Basic load ratings				Limiting speeds		Bearing numbers	Abutment dimensions		Mass kg (approx.)
mm				dynamic	static	dynamic	static	grease	oil		mm	mm	
F_w	D	C	r_s min ¹⁾	N		kgf				D_a max			r_{as} max
470 ^{+0.108} _{+0.068}	560	140	4	1 500 000	4 250 000	153 000	430 000	550	850	RNA4984	544	3	51.60
490 ^{+0.108} _{+0.068}	600	160	4	1 750 000	4 600 000	179 000	470 000	550	800	RNA4988	584	3	66.90

Note 1) Allowable minimum chamfer dimension r_s .

2) Max. allowable dimension of radius r_a for corner roundness on shaft/housing.

With inner ring

Type NA49
Type NA59
Type NA69
Type NK+IR
Type NKS+IR

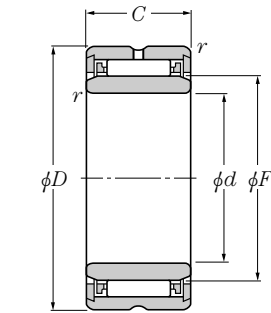

Type NA49 ($\phi d \leq 9\text{mm}$)

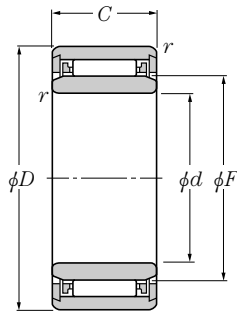

Type NK+IR ($\phi d \leq 9\text{mm}$)
Type NKS+IR

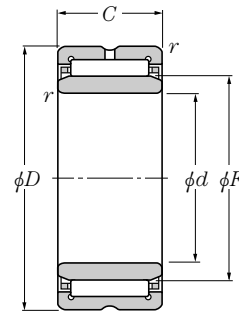

Type NA49 · R ($\phi d \geq 10\text{mm}$)
Type NA59
Type NA69 · R
Type NK · R+IR ($\phi d \geq 10\text{mm}$)

d 5~15mm

Boundary dimensions						Basic load ratings				Limiting speeds		Bearing numbers
mm						dynamic	static	dynamic	static	grease	oil	
d	D	C	$r_{s \min}^{1)}$	F	$s^{2)}$	C_r	C_{or}	C_r	C_{or}			
						N						
						kgf						
5	13	10	0.15	7	—	2 670	2 350	272	239	23 000	34 000	NA495T2
	15	12	0.3	8	1.5	4 000	4 100	410	420	21 000	32 000	NK8/12T2+IR5×8×12
	15	16	0.3	8	2	4 850	5 200	495	535	21 000	32 000	NK8/16T2+IR5×8×16
6	15	10	0.15	8	—	3 150	3 000	320	305	21 000	32 000	NA496T2T
	16	12	0.3	9	1.5	4 550	5 000	465	510	20 000	30 000	NK9/12T2+IR6×9×12
	16	16	0.3	9	2	5 500	6 400	560	650	20 000	30 000	NK9/16T2+IR6×9×16
	19	13	0.3	10	1.5	5 500	5 450	560	555	19 000	28 000	NKS10+IR6×10×13
7	17	10	0.15	9	—	3 600	3 650	365	375	20 000	30 000	NA497
	17	12	0.3	10	1.5	4 550	5 100	460	520	19 000	28 000	NK10/12T2+IR7×10×12
	17	16	0.3	10	2	5 450	6 450	555	660	19 000	28 000	8E-NK10/16CT+IR7×10×16
	22	16	0.3	12	2	9 000	9 400	920	960	17 000	26 000	NKS12+IR7×12×16
8	19	11	0.15	10	—	5 250	5 150	535	525	19 000	28 000	NA498CT
	25	16	0.3	14	2	8 950	9 650	915	985	16 000	24 000	NKS14+IR8×14×16
9	19	12	0.3	12	1.5	5 000	6 100	510	620	17 000	26 000	NK12/12+IR9×12×12
	19	16	0.3	12	2	6 000	7 700	615	785	17 000	26 000	NK12/16+IR9×12×16
	20	11	0.3	12	—	4 850	4 900	495	500	17 000	26 000	NA499
	26	16	0.3	15	2	10 100	11 500	1 030	1 170	15 000	23 000	NKS15+IR9×15×16
10	22	13	0.3	14	0.5	8 600	9 200	875	935	16 000	24 000	NA4900R
	22	16	0.3	14	0.5	10 300	11 500	1 050	1 170	16 000	24 000	NK14/16R+IR10×14×16
	22	20	0.3	14	0.5	13 000	15 600	1 330	1 590	16 000	24 000	NK14/20R+IR10×14×20
	28	16	0.3	16	1.5	12 600	13 900	1 290	1 410	15 000	23 000	NKS16+IR10×16×16
12	24	13	0.3	16	0.5	9 550	10 900	975	1 110	15 000	23 000	NA4901R
	24	16	0.3	16	0.5	12 200	14 900	1 240	1 520	15 000	23 000	NK16/16R+IR12×16×16
	24	20	0.3	16	0.5	14 600	18 800	1 490	1 920	15 000	23 000	NK16/20R+IR12×16×20
	24	22	0.3	16	1	15 400	20 000	1 570	2 040	15 000	23 000	NA6901R
	30	16	0.3	18	1.5	11 600	12 800	1 180	1 300	14 000	21 000	NKS18+IR12×18×16
15	27	16	0.3	19	0.5	13 300	17 400	1 350	1 780	14 000	21 000	NK19/16R+IR15×19×16
	27	20	0.3	19	0.5	16 000	22 200	1 630	2 260	14 000	21 000	NK19/20R+IR15×19×20
	28	13	0.3	20	0.5	10 300	12 800	1 050	1 310	13 000	20 000	NA4902R

Note 1) Allowable minimum chamfer dimension r . 2) Allowable axial stroking value of inner ring against outer ring.

3) Max. allowable dimension of radius r_a for corner roundness on shaft/housing.

Remarks: Nominal code number of inner ring (IR) comprises the codes of IR bore diameter×outer diameter×width.

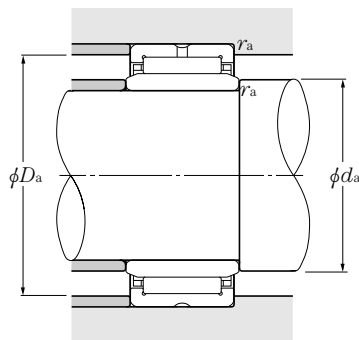
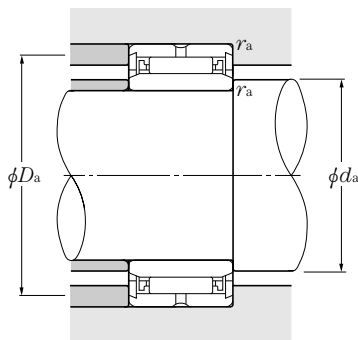
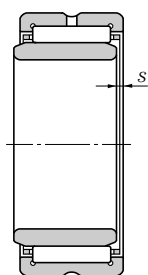

Abutment dimensions			Mass kg (approx.)
d_a min	mm D_a max	r_{as} ³⁾ max	
6.2	8.5	0.15	0.007
7	9.5	0.3	0.012
7	9.5	0.3	0.016
8	9.5	0.15	0.009
8	10.5	0.3	0.013
8	10.5	0.3	0.017
8	12	0.3	0.02
9	10.5	0.15	0.010
9	11.5	0.3	0.014
9	11.5	0.3	0.018
9	14.5	0.3	0.035
10	12	0.15	0.016
10	16.5	0.3	0.048
11	13.5	0.3	0.018
11	13.5	0.3	0.022
11	14	0.3	0.017
11	17.5	0.3	0.042
12	20	0.3	0.024
12	20	0.3	0.030
12	20	0.3	0.038
12	19	0.3	0.054
14	22	0.3	0.026
14	22	0.3	0.033
14	22	0.3	0.042
14	22	0.3	0.046
14	21	0.3	0.056
17	25	0.3	0.039
17	25	0.3	0.045
17	26	0.3	0.036

With inner ring

Type NA49
 Type NA59
 Type NA69
 Type NK+IR
 Type NKS+IR

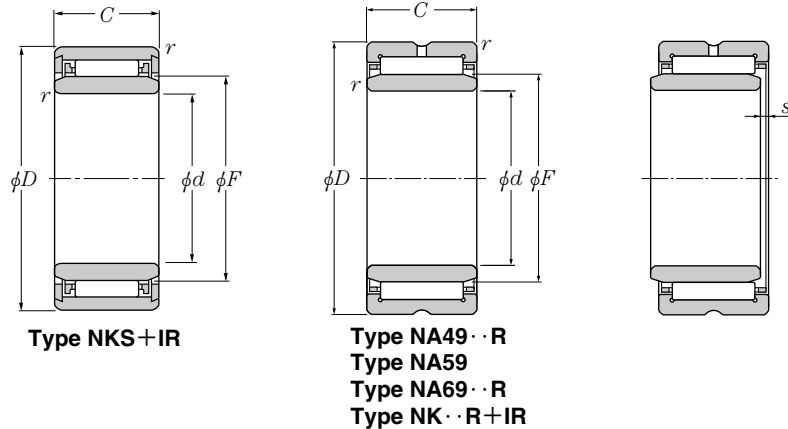

d 15~28mm

Boundary dimensions						Basic load ratings				Limiting speeds		Bearing numbers
mm						dynamic	static	dynamic	static	grease	oil	
d	D	C	$r_{s \min}^{1)}$	F	$s^{2)}$	C_r	C_{or}	C_r	C_{or}			min^{-1}
						N						
						kgf						
15	28	18	0.3	20	0.5	14 100	19 100	1 440	1 950	13 000	20 000	NA5902CT
	28	23	0.3	20	1	17 600	25 300	1 790	2 580	13 000	20 000	NA6902R
	35	20	0.6	22	1.5	17 700	23 300	1 810	2 380	12 000	18 000	NKS22+IR15×22×20
17	29	16	0.3	21	0.5	13 700	18 700	1 400	1 910	13 000	19 000	NK21/16R+IR17×21×16
	29	20	0.3	21	0.5	17 400	25 400	1 770	2 590	13 000	19 000	NK21/20R+IR17×21×20
	30	13	0.3	22	0.5	11 200	14 600	1 140	1 490	12 000	18 000	NA4903R
	30	18	0.3	22	0.5	15 200	21 700	1 550	2 210	12 000	18 000	NA5903
	30	23	0.3	22	1	18 200	27 200	1 850	2 770	12 000	18 000	NA6903R
	37	20	0.6	24	1.5	18 400	25 200	1 880	2 570	11 000	17 000	NKS24+IR17×24×20
20	32	16	0.3	24	0.5	15 200	22 300	1 550	2 280	11 000	17 000	NK24/16R+IR20×24×16
	32	20	0.3	24	0.5	18 600	28 800	1 890	2 930	11 000	17 000	NK24/20R+IR20×24×20
	37	17	0.3	25	0.8	21 300	25 500	2 170	2 600	11 000	16 000	NA4904RCT
	37	23	0.3	25	0.8	28 400	37 000	2 900	3 750	11 000	16 000	NA5904
	37	30	0.3	25	1	36 500	50 500	3 700	5 150	11 000	16 000	NA6904R
	42	20	0.6	28	2	18 100	25 800	1 850	2 630	9 500	14 000	NKS28+IR20×28×20
22	34	16	0.3	26	0.5	15 600	23 600	1 590	2 410	10 000	15 000	NK26/16R+IR22×26×16
	34	20	0.3	26	0.5	19 100	30 500	1 940	3 100	10 000	15 000	NK26/20R+IR22×26×20
	39	17	0.3	28	0.8	23 200	29 300	2 360	2 990	9 500	14 000	NA49/22R
	39	23	0.3	28	0.8	26 400	37 500	2 690	3 850	9 500	14 000	NA59/22
	39	30	0.3	28	0.5	40 000	58 500	4 050	6 000	9 500	14 000	NA69/22R
25	38	20	0.3	29	1	22 200	34 000	2 270	3 450	9 500	14 000	NK29/20R+IR25×29×20
	38	30	0.3	29	1.5	27 500	50 500	2 810	5 150	9 500	14 000	NK29/30R+IR25×29×30
	42	17	0.3	30	0.8	24 000	31 500	2 450	3 200	8 500	13 000	NA4905R
	42	23	0.3	30	0.8	30 500	43 000	3 150	4 350	8 500	13 000	NA5905
	42	30	0.3	30	1	41 500	63 000	4 200	6 400	8 500	13 000	NA6905R
	47	22	0.6	32	2	24 000	35 000	2 450	3 550	8 500	13 000	NKS32+IR25×32×22
28	42	20	0.3	32	1	23 500	37 500	2 400	3 850	8 500	13 000	NK32/20R+IR28×32×20
	42	30	0.3	32	1.5	34 000	60 500	3 450	6 150	8 500	13 000	NK32/30R+IR28×32×30
	45	17	0.3	32	0.8	24 800	33 500	2 530	3 400	8 500	13 000	NA49/28RCT
	45	23	0.3	32	0.8	32 000	45 500	3 250	4 650	8 500	13 000	NA59/28

Note 1) Allowable minimum chamfer dimension r . 2) Allowable axial stroking value of inner ring against outer ring.

3) Max. allowable dimension of radius r_a for corner roundness on shaft/housing.

Remarks: Nominal code number of inner ring (IR) comprises the codes of IR bore diameter×outer diameter×width.

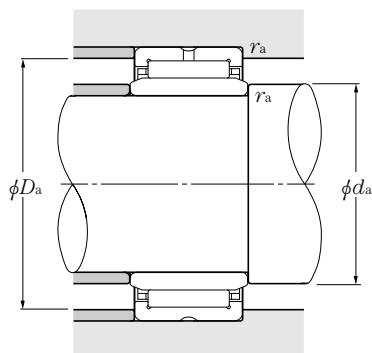

Abutment dimensions			Mass
d_a	mm		kg
min	max	$r_{as}^{3)}$ max	(approx.)
17	26	0.3	0.052
17	26	0.3	0.064
19	25	0.6	0.094
19	27	0.3	0.042
19	27	0.3	0.053
19	28	0.3	0.037
19	28	0.3	0.056
19	28	0.3	0.069
21	27	0.6	0.1
22	30	0.3	0.049
22	30	0.3	0.061
22	35	0.3	0.074
22	35	0.3	0.115
22	35	0.3	0.141
24	31	0.6	0.129
24	32	0.3	0.046
24	32	0.3	0.064
24	37	0.3	0.080
24	37	0.3	0.134
24	37	0.3	0.154
27	36	0.3	0.079
27	36	0.3	0.123
27	40	0.3	0.088
27	40	0.3	0.139
27	40	0.3	0.162
29	35.5	0.6	0.162
30	40	0.3	0.096
30	40	0.3	0.146
30	43	0.3	0.098
30	43	0.3	0.142

With inner ring

Type NA49

Type NA59

Type NA69

Type NK+IR

Type NKS+IR

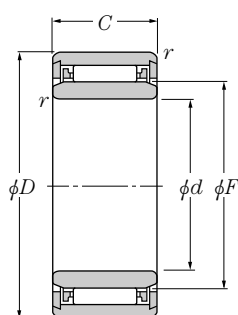

Type NKS+IR
($\phi d \leq 30\text{mm}$)

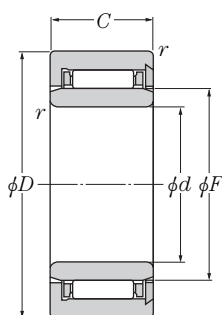

Type NKS+IR
($\phi d \geq 35\text{mm}$)

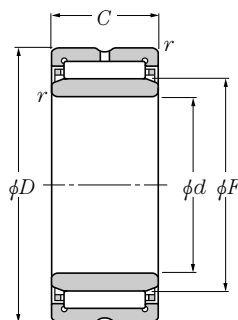

Type NA49 · R
Type NA59
Type NA69 · R ($\phi d \leq 30\text{mm}$)
Type NK · R + IR

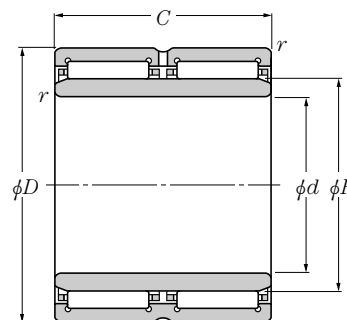

Type NA69 · R
($\phi d \geq 32\text{mm}$)

d 28~45mm

Boundary dimensions						Basic load ratings				Limiting speeds		Bearing numbers
mm						dynamic	static	dynamic	static	min ⁻¹		
d	D	C	r _{s min} ¹⁾	F	S ²⁾	C _r	C _{or}	C _r	C _{or}	grease	oil	
28	45	30	0.3	32	1	43 000	67 000	4 350	6 850	8 500	13 000	NA69/28R
	45	20	0.3	35	0.5	24 800	41 500	2 520	4 250	7 500	11 000	NK35/20RCT + IR30 × 35 × 20
30	45	30	0.3	35	1	36 000	66 500	3 650	6 800	7 500	11 000	NK35/30R + IR30 × 35 × 30
	47	17	0.3	35	0.8	25 500	35 500	2 600	3 600	7 500	11 000	NA4906R
	47	23	0.3	35	0.8	32 500	48 500	3 350	4 950	7 500	11 000	NA5906
	47	30	0.3	35	1	42 500	67 500	4 300	6 900	7 500	11 000	NA6906R
	52	22	0.6	37	2	26 300	41 000	2 680	4 150	7 500	11 000	NKS37 + IR30 × 37 × 22
32	47	20	0.3	37	0.5	25 300	43 500	2 580	4 400	7 500	11 000	NK37/20R + IR32 × 37 × 20
	47	30	0.3	37	1	36 500	69 500	3 750	7 100	7 500	11 000	NK37/30R + IR32 × 37 × 30
	52	20	0.6	40	0.8	31 500	47 500	3 200	4 850	6 500	10 000	NA49/32R
	52	27	0.6	40	0.8	38 000	61 000	3 850	6 250	6 500	10 000	NA59/32
	52	36	0.6	40	0.5	47 500	82 000	4 850	8 350	6 500	10 000	NA69/32R
35	50	20	0.3	40	0.5	26 400	47 000	2 700	4 800	6 500	10 000	NK40/20R + IR35 × 40 × 20
	50	30	0.3	40	1	38 500	76 000	3 900	7 750	6 500	10 000	NK40/30R + IR35 × 40 × 30
	55	20	0.6	42	0.8	32 000	50 000	3 300	5 100	6 500	9 500	NA4907R
	55	27	0.6	42	0.8	39 000	64 500	3 950	6 550	6 500	9 500	NA5907
	55	36	0.6	42	0.5	49 000	86 500	5 000	8 800	6 500	9 500	NA6907R
	58	22	0.6	43	1.5	29 100	49 000	2 960	5 000	6 500	9 500	NKS43 + IR35 × 43 × 22
38	53	20	0.3	43	0.5	27 500	51 000	2 810	5 200	6 500	9 500	NK43/20R + IR38 × 43 × 20
	53	30	0.3	43	1	40 000	82 000	4 100	8 400	6 500	9 500	NK43/30R + IR38 × 43 × 30
40	55	20	0.3	45	0.5	28 000	52 500	2 860	5 400	6 000	9 000	NK45/20R + IR40 × 45 × 20
	55	30	0.3	45	1	41 000	85 500	4 150	8 700	6 000	9 000	NK45/30R + IR40 × 45 × 30
	62	22	0.6	48	1	43 500	66 500	4 450	6 800	5 500	8 500	NA4908RCT
	62	30	0.6	48	1	53 000	92 500	5 450	9 450	5 500	8 500	NA5908
	62	40	0.6	48	0.5	67 000	116 000	6 850	11 800	5 500	8 500	NA6908R
	65	22	1	50	1.5	31 500	57 000	3 200	5 800	5 500	8 000	NKS50 + IR40 × 50 × 22
42	57	20	0.3	47	0.5	28 800	55 500	2 940	5 650	5 500	8 500	NK47/20RCT + IR42 × 47 × 20
	57	30	0.3	47	1	42 500	91 500	4 350	9 350	5 500	8 500	NK47/30R + IR42 × 47 × 30
45	62	25	0.6	50	1.5	38 500	74 500	3 950	7 550	5 500	8 000	NK50/25RCT + IR45 × 50 × 25

Note 1) Allowable minimum chamfer dimension r . 2) Allowable axial stroking value of inner ring against outer ring.

3) Max. allowable dimension of radius r_a for corner roundness on shaft/housing.

Remarks: Nominal code number of inner ring (IR) comprises the codes of IR bore diameter × outer diameter × width.

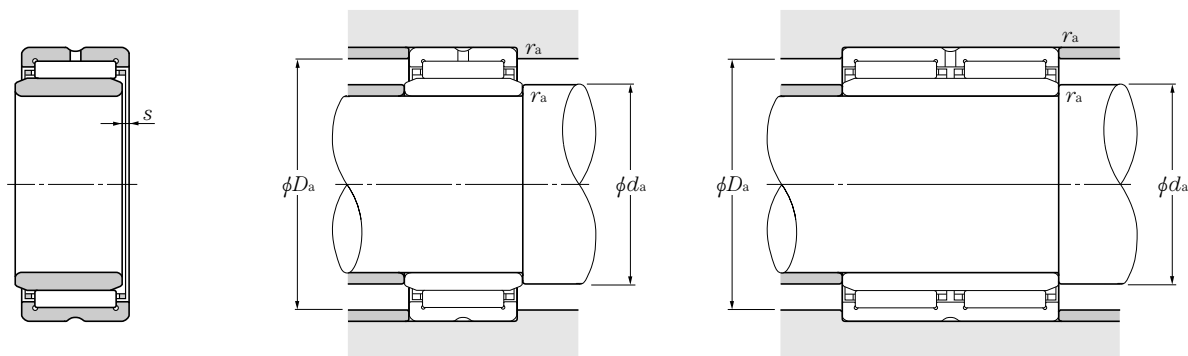

Abutment dimensions			Mass kg (approx.)
d_a min	mm D_a max	r_{as} ³⁾ max	
30	43	0.3	0.179
32	43	0.3	0.112
32	43	0.3	0.171
32	45	0.3	0.101
32	45	0.3	0.152
32	45	0.3	0.185
34	40.5	0.6	0.184
34	45	0.3	0.117
34	45	0.3	0.170
36	48	0.6	0.157
36	48	0.6	0.241
36	48	0.6	0.286
37	48	0.3	0.130
37	48	0.3	0.193
39	51	0.6	0.171
39	51	0.6	0.256
39	51	0.6	0.310
39	46.5	0.6	0.229
40	51	0.3	0.134
40	51	0.3	0.207
42	53	0.3	0.143
42	53	0.3	0.216
44	58	0.6	0.232
44	58	0.6	0.348
44	58	0.6	0.426
45	53.5	1	0.263
44	55	0.3	0.148
44	55	0.3	0.222
48	58	0.6	0.229

With inner ring

Type NA49
 Type NA59
 Type NA69
 Type NK+IR
 Type NKS+IR

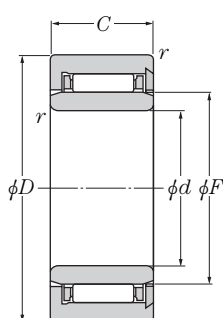

Type NKS+IR

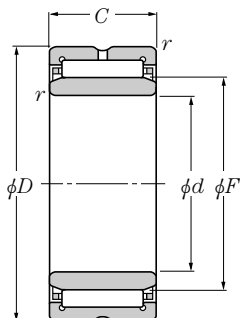

Type NA49·R
 Type NA59
 Type NK·R+IR

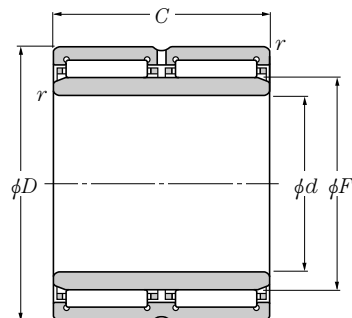

Type NA69·R

d 45~70mm

Boundary dimensions						Basic load ratings				Limiting speeds		Bearing numbers
mm						dynamic	static	dynamic	static	min ⁻¹		
d	D	C	r _{s min} ¹⁾	F	s ²⁾	C _r	C _{or}	C _r	C _{or}	grease	oil	
45	62	35	0.6	50	2	51 000	106 000	5 200	10 800	5 500	8 000	NK50/35R+IR45×50×35
	68	22	0.6	52	1	46 000	73 000	4 700	7 450	5 000	7 500	NA4909R
	68	30	0.6	52	1	56 000	101 000	5 700	10 300	5 000	7 500	NA5909
	68	40	0.6	52	0.5	70 500	127 000	7 200	13 000	5 000	7 500	NA6909R
	72	22	1	55	1.5	33 500	63 000	3 400	6 450	5 000	7 500	NKS55+IR45×55×22
50	68	25	0.6	55	1.5	41 000	82 000	4 150	8 400	5 000	7 500	NK55/25R+IR50×55×25
	68	35	0.6	55	2	54 000	118 000	5 500	12 000	5 000	7 500	NK55/35R+IR50×55×35
	72	22	0.6	58	1	48 000	80 000	4 900	8 150	4 700	7 000	NA4910R
	72	30	0.6	58	1	58 000	110 000	5 950	11 200	4 700	7 000	NA5910
	72	40	0.6	58	0.5	74 000	139 000	7 500	14 200	4 700	7 000	NA6910R
55	80	28	1.1	60	2.5	44 500	85 000	4 500	8 700	4 300	6 500	NKS60+IR50×60×28
	72	25	0.6	60	1.5	41 000	85 000	4 200	8 700	4 300	6 500	NK60/25R+IR55×60×25
	72	35	0.6	60	2	57 000	130 000	5 800	13 200	4 300	6 500	NK60/35R+IR55×60×35
	80	25	1	63	1.5	58 500	99 500	6 000	10 100	4 300	6 500	NA4911R
	80	34	1	63	1.5	76 500	140 000	7 800	14 300	4 300	6 500	NA5911
60	80	45	1	63	1.5	94 000	183 000	9 600	18 600	4 300	6 500	NA6911R
	85	28	1.1	65	2.5	47 000	94 000	4 800	9 600	4 000	6 000	NKS65+IR55×65×28
	82	25	1	68	1	44 500	89 000	4 500	9 050	4 000	6 000	NK68/25R+IR60×68×25
	82	35	0.6	68	1	63 000	139 000	6 400	14 200	4 000	6 000	NK68/35R+IR60×68×35
	85	25	1	68	1.5	61 500	108 000	6 250	11 000	4 000	6 000	NA4912R
65	85	34	1	68	1.5	80 500	153 000	8 200	15 600	4 000	6 000	NA5912
	85	45	1	68	1.5	95 500	191 000	9 750	19 400	4 000	6 000	NA6912R
	90	28	1.1	70	2.5	49 500	103 000	5 050	10 500	3 700	5 500	NKS70+IR60×70×28
	90	25	0.6	73	1	54 000	100 000	5 500	10 200	3 700	5 500	NK73/25R+IR65×73×25
	90	25	1	72	1.5	62 500	112 000	6 350	11 400	3 700	5 500	NA4913R
70	90	34	1	72	1.5	84 000	165 000	8 600	16 800	3 700	5 500	NA5913
	90	35	0.6	73	1	76 500	156 000	7 800	16 000	3 700	5 500	NK73/35R+IR65×73×35
	90	45	1	72	1.5	97 000	198 000	9 900	20 200	3 700	5 500	NA6913R
	95	28	1.1	75	2.5	50 500	109 000	5 150	11 100	3 700	5 500	NKS75+IR65×75×28
70	95	25	1	80	0.8	57 000	119 000	5 800	12 200	3 300	5 000	NK80/25R+IR70×80×25

Note 1) Allowable minimum chamfer dimension r . 2) Allowable axial stroking value of inner ring against outer ring.

3) Max. allowable dimension of radius r_a for corner roundness on shaft/housing.

Remarks: Nominal code number of inner ring (IR) comprises the codes of IR bore diameter×outer diameter×width.

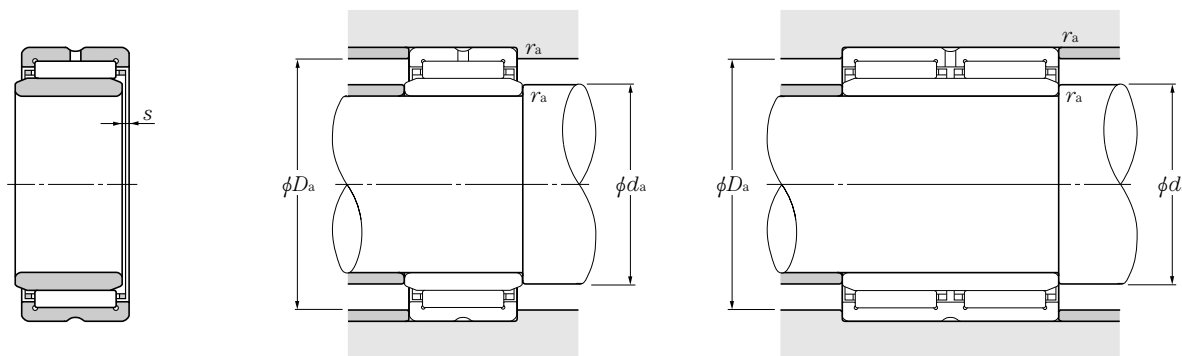

Abutment dimensions			Mass kg (approx.)
d_a min	mm D_a max	r_{as} ³⁾ max	
48	58	0.6	0.322
49	64	0.6	0.270
49	64	0.6	0.396
49	64	0.6	0.437
50	58.5	1	0.351
<hr/>			
53	64	0.6	0.271
53	64	0.6	0.379
54	68	0.6	0.276
54	68	0.6	0.498
54	68	0.6	0.529
56.5	64	1.1	0.518
<hr/>			
58	68	0.6	0.271
58	68	0.6	0.379
60	75	1	0.396
60	75	1	0.559
60	75	1	0.726
61.5	69	1.1	0.562
<hr/>			
65	77	0.6	0.393
64	78	0.6	0.551
65	80	1	0.427
65	80	1	0.614
65	80	1	0.758
66.5	74	1.1	0.591
<hr/>			
69	86	0.6	0.466
70	85	1	0.454
70	85	1	0.655
69	86	0.6	0.660
70	85	1	0.779
71.5	79	1.1	0.642
<hr/>			
75	90	1	0.525

With inner ring

Type NA48
 Type NA49
 Type NA59
 Type NA69
 Type NK+IR
 Type NKS+IR

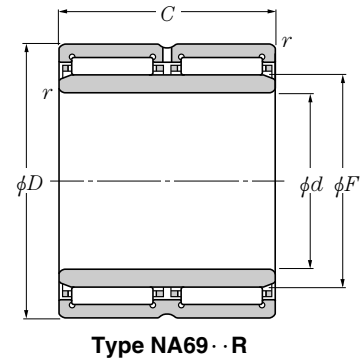
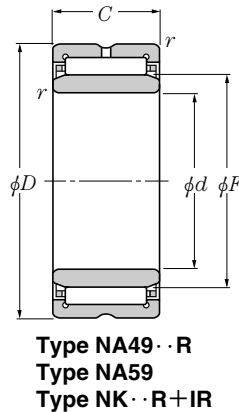
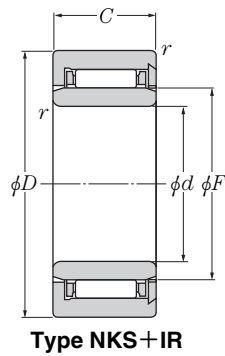

d 70~95mm

Boundary dimensions						Basic load ratings				Limiting speeds		Bearing numbers
mm						dynamic	static	dynamic	static	grease	oil	
d	D	C	$r_{s\min}^{1)}$	F	$s^{2)}$	C_r	C_{or}	C_r	C_{or}			min^{-1}
						N						
						kgf						
70	95	35	1	80	0.8	79 500	184 000	8 150	18 700	3 300	5 000	NK80/35R+IR70×80×35
	100	28	1.1	80	2.5	53 000	118 000	5 400	12 100	3 300	5 000	NKS80+IR70×80×28
	100	30	1	80	1.5	85 500	156 000	8 750	15 900	3 300	5 000	NA4914R
	100	40	1	80	1.5	103 000	187 000	10 500	19 100	3 300	5 000	NA5914
	100	54	1	80	1	130 000	267 000	13 300	27 200	3 300	5 000	NA6914R
75	105	25	1	85	1	70 500	123 000	7 200	12 600	3 100	4 700	NK85/25R+IR75×85×25
	105	30	1	85	1.5	87 000	162 000	8 900	16 500	3 100	4 700	NA4915R
	105	35	1	85	1	100 000	193 000	10 200	19 700	3 100	4 700	NK85/35R+IR75×85×35
	105	40	1	85	1.5	109 000	205 000	11 100	20 900	3 100	4 700	NA5915
	105	54	1	85	1	132 000	277 000	13 500	28 300	3 100	4 700	NA6915R
80	110	32	1.1	90	1.5	64 000	157 000	6 550	16 000	2 900	4 400	NKS90+IR75×90×32
	110	25	1	90	1	71 500	128 000	7 300	13 100	2 900	4 400	NK90/25R+IR80×90×25
	110	30	1	90	1.5	90 500	174 000	9 250	17 700	2 900	4 400	NA4916R
	110	35	1	90	1	104 000	208 000	10 600	21 200	2 900	4 400	NK90/35R+IR80×90×35
	110	40	1	90	1.5	115 000	223 000	11 700	22 700	2 900	4 400	NA5916
	110	54	1	90	1.5	138 000	298 000	14 000	30 500	2 900	4 400	NA6916R
85	115	32	1.1	95	2.5	65 500	165 000	6 700	16 800	2 800	4 200	NKS95+IR80×95×32
	115	26	1	95	1.5	74 500	137 000	7 600	14 000	2 800	4 200	NK95/26R+IR85×95×26
	115	36	1	95	1.5	108 000	223 000	11 100	22 700	2 800	4 200	NK95/36R+IR85×95×36
	120	32	1.1	100	3	61 000	153 000	6 250	15 600	2 700	4 000	NKS100+IR85×100×32
	120	35	1.1	100	1	112 000	237 000	11 500	24 200	2 700	4 000	NA4917R
	120	46	1.1	100	1.5	137 000	290 000	14 000	29 600	2 700	4 000	NA5917
90	120	63	1.1	100	1	169 000	400 000	17 300	41 000	2 700	4 000	NA6917R
	120	26	1	100	1.5	73 500	137 000	7 500	14 000	2 700	4 000	NK100/26R+IR90×100×26
	120	36	1	100	1.5	107 000	223 000	11 000	22 800	2 700	4 000	NK100/36R+IR90×100×36
	125	32	1.1	105	2	67 500	176 000	6 850	18 000	2 500	3 800	NKS105+IR90×105×32
	125	35	1.1	105	1	116 000	252 000	11 900	25 700	2 500	3 800	NA4918R
	125	46	1.1	105	1	143 000	310 000	14 600	32 000	2 500	3 800	NA5918
95	125	63	1.1	105	1	175 000	425 000	17 900	43 500	2 500	3 800	NA6918R
95	125	26	1	105	1.5	76 500	147 000	7 800	14 900	2 500	3 800	NK105/26R+IR95×105×26

Note 1) Allowable minimum chamfer dimension r . 2) Allowable axial stroking value of inner ring against outer ring.

3) Max. allowable dimension of radius r_a for corner roundness on shaft/housing.

Remarks: Nominal code number of inner ring (IR) comprises the codes of IR bore diameter×outer diameter×width.

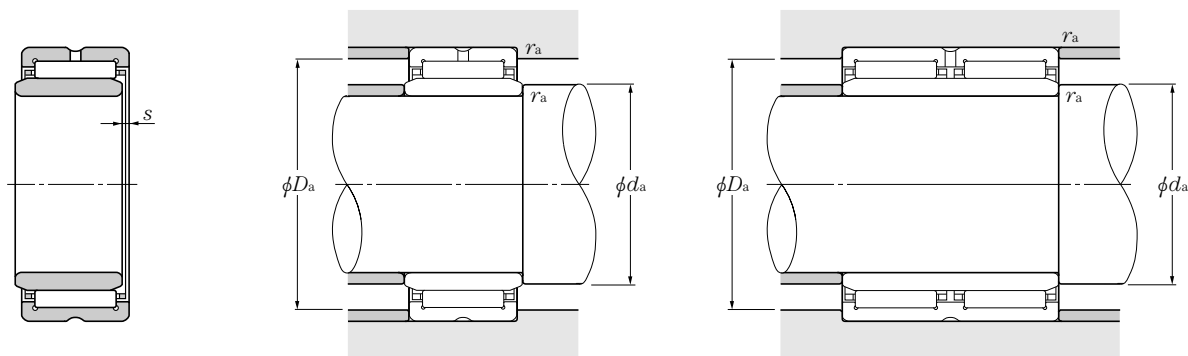

Abutment dimensions			Mass kg (approx.)
d_a min	mm D_a max	r_{as} ³⁾ max	
75	90	1	0.738
76.5	84	1.1	0.663
75	95	1	0.727
75	95	1	1.06
75	95	1	1.34
80	100	1	0.642
80	100	1	0.776
80	100	1	0.853
80	100	1	1.13
80	100	1	1.45
81.5	94	1.1	1.19
85	105	1	0.680
85	105	1	0.820
85	105	1	0.959
85	105	1	1.15
85	105	1	1.53
86.5	99	1.1	1.28
90	110	1	0.644
90	110	1	1.05
91.5	104	1.1	1.2
91.5	113.5	1	1.24
91.5	113.5	1	1.76
91.5	104	1.1	2.25
95	115	1	0.781
95	115	1	1.09
96.5	109	1.1	1.24
96.5	118.5	1	1.84
96.5	118.5	1	2.44
96.5	109	1.1	2.37
100	120	1	0.819

With inner ring

Type NA48
 Type NA49
 Type NA59
 Type NA69
 Type NK+IR
 Type NKS+IR

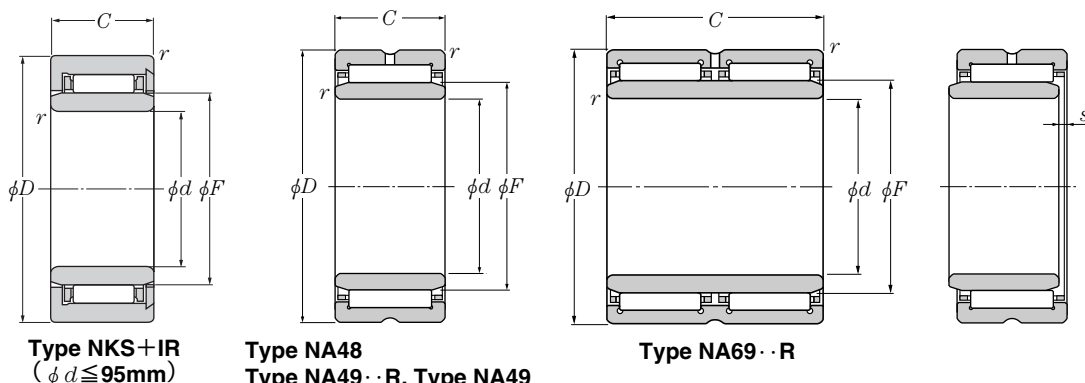

Type NKS+IR
($\phi d \leq 95\text{mm}$)

Type NA48
Type NA49·R, Type NA49
Type NA59
Type NK·R+IR, Type NK+IR
Type NKS+IR ($\phi d \geq 100\text{mm}$)

Type NA69·R

d 95~140mm

Boundary dimensions						Basic load ratings				Limiting speeds		Bearing numbers
mm						dynamic	static	dynamic	static	min ⁻¹		
d	D	C	$r_{s\min}^{1)}$	F	$s^{2)}$	C_r	C_{or}	C_r	C_{or}	grease	oil	
						N						
						kgf						
95	125	36	1	105	1.5	111 000	238 000	11 400	24 300	2 500	3 800	NK105/36R+IR95×105×36
	130	32	1.1	110	3	64 500	170 000	6 600	17 300	2 400	3 600	NKS110+IR95×110×32
	130	35	1.1	110	1	118 000	260 000	12 000	26 500	2 400	3 600	NA4919R
	130	46	1.1	110	1	149 000	335 000	15 200	34 000	2 400	3 600	NA5919
	130	63	1.1	110	1	177 000	440 000	18 100	45 000	2 400	3 600	NA6919R
100	130	30	1.1	110	1.5	97 500	204 000	9 950	20 800	2 400	3 600	NK110/30R+IR100×110×30
	130	40	1.1	110	2	129 000	292 000	13 100	29 700	2 400	3 600	NK110/40R+IR100×110×40
	135	32	1.1	115	1.5	90 500	199 000	9 250	20 300	2 300	3 500	NKS115+IR100×115×32
	140	40	1.1	115	2	127 000	260 000	12 900	26 500	2 300	3 500	NA4920
	140	54	1.1	115	2	182 000	395 000	18 600	40 500	2 300	3 500	NA5920
110	140	30	1	120	0.8	93 500	210 000	9 550	21 400	2 200	3 300	NA4822
	140	40	1.1	120	—	113 000	268 000	11 500	27 300	2 200	3 300	NK120/40+IR110×120×40
	150	40	1.1	125	2	131 000	279 000	13 300	28 400	2 100	3 200	NA4922
	150	54	1.1	125	2	193 000	440 000	19 700	45 000	2 100	3 200	NA5922
120	150	30	1	130	0.8	99 500	233 000	10 100	23 800	2 100	3 100	NA4824
	150	40	1.1	130	—	116 000	283 000	11 800	28 800	2 100	3 100	NK130/40+IR120×130×40
	160	40	2	135	2.5	135 000	298 000	13 800	30 500	2 000	3 000	NKS135+IR120×135×40
	165	45	1.1	135	2	180 000	380 000	18 300	38 500	2 000	3 000	NA4924
	165	60	1.1	135	2	246 000	530 000	25 100	54 000	2 000	3 000	NA5924
130	165	35	1.1	145	1	118 000	305 000	12 100	31 000	1 900	2 800	NA4826
	170	32	1.5	145	—	111 000	238 000	11 300	24 300	1 900	2 800	NK145/32+IR130×145×32
	170	42	1.5	145	—	153 000	360 000	15 600	36 500	1 900	2 800	NK145/42+IR130×145×42
	180	50	1.5	150	1.5	202 000	455 000	20 600	46 500	1 800	2 700	NA4926
	180	52	2	150	3	202 000	455 000	20 600	46 500	1 800	2 700	NKS150+IR130×150×52
	180	67	1.5	150	1.5	296 000	690 000	30 000	70 500	1 800	2 700	NA5926
140	175	35	1.1	155	1	121 000	315 000	12 300	32 500	1 700	2 600	NA4828
	180	32	1.5	155	—	114 000	252 000	11 600	25 700	1 700	2 600	NK155/32+IR140×155×32
	180	42	1.5	155	—	156 000	380 000	16 000	38 500	1 700	2 600	NK155/42+IR140×155×42
	190	50	1.5	160	1.5	209 000	485 000	21 300	49 500	1 700	2 500	NA4928
	190	52	2	160	3	209 000	485 000	21 300	49 500	1 700	2 500	NKS160+IR140×160×52

Note 1) Allowable minimum chamfer dimension r . 2) Allowable axial stroking value of inner ring against outer ring.

3) Max. allowable dimension of radius r_a for corner roundness on shaft/housing.

Remarks: Nominal code number of inner ring (IR) comprises the codes of IR bore diameter×outer diameter×width.

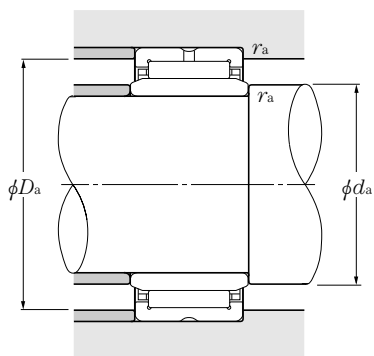

Abutment dimensions			Mass kg (approx.)
d_a min	mm D_a max	r_{as} ³⁾ max	
100	120	1	1.15
101.5	114	1.1	1.29
101.5	123.5	1	1.36
101.5	123.5	1	1.98
101.5	123.5	1	2.63
106.5	123.5	1	0.990
106.5	123.5	1	1.34
106.5	128.5	1.1	1.32
106.5	133.5	1	1.93
106.5	133.5	1	2.85
115	135	1	1.11
116.5	133.5	1	1.49
116.5	143.5	1	2.08
116.5	143.5	1	2.98
125	145	1	1.17
126.5	143.5	1	1.57
129	151	2	2.2
126.5	158.5	1	2.84
126.5	158.5	1	3.92
136.5	158.5	1	1.60
138	162.5	1.5	1.90
138	162.5	1.5	2.54
138	172	1.5	3.90
139	171	2	4.07
138	172	1.5	5.60
146.5	168.5	1	1.82
148	172	1.5	2.04
148	172	1.5	2.69
148	182	1.5	4.05
149	181	2	4.23

With inner ring

Type NA48
 Type NA49
 Type NA59
 Type NK+IR
 Type NKS+IR

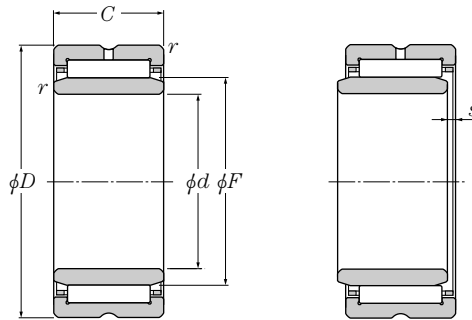

d 140~320mm

Boundary dimensions						Basic load ratings				Limiting speeds		Bearing numbers
mm						dynamic	static	dynamic	static	grease	oil	
d	D	C	$r_{s\min}^{1)}$	F	$s^{2)}$	N	N	kgf	kgf			
						C_r	C_{or}	C_r	C_{or}			
140	190	67	1.5	160	1.5	315 000	760 000	32 000	77 500	1 700	2 500	NA5928
	190	32	1.5	165	—	117 000	265 000	11 900	27 000	1 600	2 400	NK165/32+IR150×165×32
150	190	40	1.1	165	1.5	152 000	390 000	15 500	40 000	1 600	2 400	NA4830
	190	42	1.5	165	—	160 000	400 000	16 300	40 500	1 600	2 400	NK165/42+IR150×165×42
	200	52	2	170	3	215 000	515 000	21 900	52 500	1 600	2 400	NKS170+IR150×170×52
	210	60	2	170	1.5	261 000	610 000	26 600	62 500	1 600	2 400	NA4930
160	200	40	1.1	175	1.5	160 000	425 000	16 300	43 500	1 500	2 300	NA4832
	220	60	2	180	1.5	270 000	650 000	27 600	66 500	1 500	2 200	NA4932
170	215	45	1.1	185	1.5	185 000	495 000	18 800	50 500	1 500	2 200	NA4834
	230	60	2	190	1.5	279 000	690 000	28 500	70 500	1 400	2 100	NA4934
180	225	45	1.1	195	1.5	195 000	540 000	19 800	55 000	1 400	2 100	NA4836
	250	69	2	205	1.5	375 000	890 000	38 500	90 500	1 300	2 000	NA4936
190	240	50	1.5	210	1.5	227 000	680 000	23 200	69 000	1 300	1 900	NA4838
	260	69	2	215	1.5	390 000	945 000	40 000	96 500	1 300	1 900	NA4938
200	250	50	1.5	220	1.5	231 000	705 000	23 600	71 500	1 200	1 800	NA4840
	280	80	2.1	225	1.5	505 000	1 180 000	51 500	120 000	1 200	1 800	NA4940
220	270	50	1.5	240	1.5	244 000	780 000	24 900	79 500	1 100	1 700	NA4844
	300	80	2.1	245	1.5	525 000	1 270 000	53 500	129 000	1 100	1 600	NA4944
240	300	60	2	265	2	360 000	1 080 000	37 000	110 000	1 000	1 500	NA4848
	320	80	2.1	265	2	540 000	1 350 000	55 000	138 000	1 000	1 500	NA4948
260	320	60	2	285	2	375 000	1 160 000	38 000	119 000	950	1 400	NA4852
	360	100	2.1	290	2	805 000	1 900 000	82 000	193 000	950	1 400	NA4952
280	350	69	2	305	2.5	455 000	1 300 000	46 500	133 000	850	1 300	NA4856
	380	100	2.1	310	2.5	835 000	2 030 000	85 000	207 000	850	1 300	NA4956
300	380	80	2.1	330	2	625 000	1 770 000	64 000	180 000	800	1 200	NA4860
	420	118	3	340	2	1 080 000	2 640 000	110 000	269 000	800	1 200	NA4960
320	400	80	2.1	350	2	640 000	1 850 000	65 500	189 000	750	1 100	NA4864
	440	118	3	360	2	1 120 000	2 820 000	114 000	288 000	750	1 100	NA4964

Note 1) Allowable minimum chamfer dimension r . 2) Allowable axial stroking value of inner ring against outer ring.

3) Max. allowable dimension of radius r_a for corner roundness on shaft/housing.

Remarks: Nominal code number of inner ring (IR) comprises the codes of IR bore diameter×outer diameter×width.

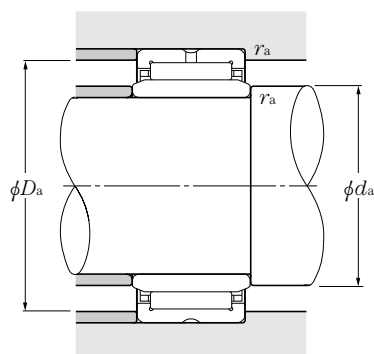

Abutment dimensions			Mass
d_a	mm		kg
min	max	$r_{as}^{(3)}$ max	(approx.)
148	182	1.5	6.18
158	182	1.5	2.32
156.5	183.5	1	2.72
158	182	1.5	2.84
159	191	2	4.59
159	201	2	5.33
166.5	193.5	1	2.90
169	211	2	5.60
176.5	208.5	1	3.99
179	221	2	5.87
186.5	218.5	1	4.19
189	241	2	8.58
198	232	1.5	5.62
199	251	2	8.68
208	242	1.5	5.84
211	269	2	12.2
228	262	1.5	6.37
231	289	2	13.5
249	291	2	10.0
251	309	2	14.7
269	311	2	10.8
271	349	2	25.9
289	341	2	15.5
291	369	2	27.5
311	369	2	22.0
313	407	2.5	42.5
331	389	2	23.2
333	427	2.5	45.2

With inner ring

Type NA48

Type NA49

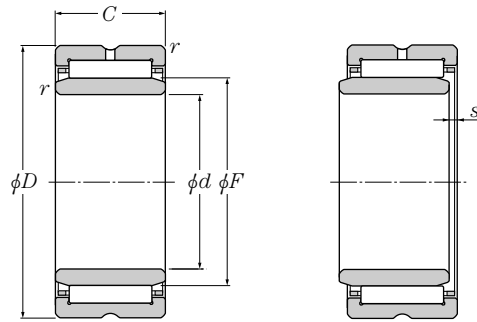

d 340~440mm

Boundary dimensions						Basic load ratings				Limiting speeds		Bearing numbers
mm						dynamic	static	dynamic	static	grease	oil	
d	D	C	$r_{s\min}^{1)}$	F	$s^{2)}$	N		kgf				
						C_r	C_{or}	C_r	C_{or}			
340	420	80	2.1	370	2	655 000	1 940 000	66 500	197 000	750	1 100	NA4868
	460	118	3	380	2	1 160 000	3 000 000	118 000	305 000	750	1 100	NA4968
360	440	80	2.1	390	2	665 000	2 020 000	68 000	206 000	650	1 000	NA4872
	480	118	3	400	2	1 200 000	3 200 000	122 000	325 000	650	1 000	NA4972
380	480	100	2.1	415	2	1 000 000	2 840 000	102 000	289 000	650	950	NA4876
	520	140	4	430	2	1 400 000	3 750 000	143 000	385 000	650	950	NA4976
400	540	140	4	450	2.5	1 450 000	4 000 000	148 000	410 000	600	900	NA4980
420	560	140	4	470	2.5	1 500 000	4 250 000	153 000	430 000	550	850	NA4984
440	600	160	4	490	2.5	1 750 000	4 600 000	179 000	470 000	550	800	NA4988

Note 1) Allowable minimum chamfer dimension r . 2) Allowable axial stroking value of inner ring against outer ring.
3) Max. allowable dimension of radius r_a for corner roundness on shaft/housing.

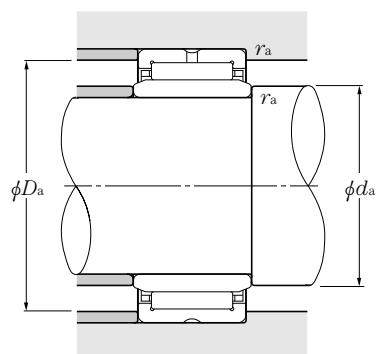

Abutment dimensions			Mass
d_a	mm		kg
min	max	$r_{as}^{(3)}$ max	(approx.)
351	409	2	24.1
353	447	2.5	47.3
371	429	2	25.7
373	467	2.5	49.0
391	469	2	44.5
396	504	3	73.6
416	524	3	76.6
436	544	3	89.8
456	584	3	123

Inch series Without inner ring

Type MR

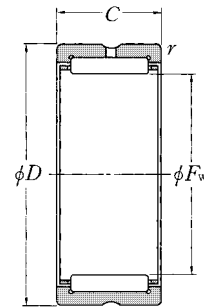

F_w 15.875~63.500mm

F_w	Boundary dimensions				dynamic N	Basic load ratings				Limiting speeds	
	mm ($\frac{1}{25.4}$ mm)					static	dynamic	static	dynamic	grease	oil
		D	C	r_s min. 1)	C_r	C_{or}	C_r	C_{or}	r/min (approx.)		
15.875($\frac{5}{8}$)	+0.027 +0.016	28.575($1\frac{1}{8}$)	19.05($\frac{3}{4}$)	0.6	16 700	16 700	1 700	1 700	17 000	25 000	
		28.575($1\frac{1}{8}$)	25.40(1)	0.6	21 500	23 000	2 190	2 350	17 000	25 000	
19.050($\frac{3}{4}$)	+0.033 +0.020	31.750($1\frac{1}{4}$)	19.05($\frac{3}{4}$)	1	19 500	21 100	1 980	2 150	14 000	21 000	
		31.750($1\frac{1}{4}$)	25.40(1)	1	25 000	29 100	2 550	2 970	14 000	21 000	
22.225($\frac{7}{8}$)	+0.033 +0.020	34.925($1\frac{3}{8}$)	19.05($\frac{3}{4}$)	1	21 900	25 600	2 240	2 610	12 000	18 000	
		34.925($1\frac{3}{8}$)	25.40(1)	1	28 200	35 500	2 870	3 600	12 000	18 000	
25.400(1)	+0.033 +0.020	38.100($1\frac{1}{2}$)	19.05($\frac{3}{4}$)	1	23 000	28 100	2 340	2 870	11 000	16 000	
		38.100($1\frac{1}{2}$)	25.40(1)	1	29 500	38 500	3 000	3 950	11 000	16 000	
28.575($1\frac{1}{8}$)	+0.033 +0.020	41.275($1\frac{5}{8}$)	25.40(1)	1	32 500	45 000	3 300	4 600	9 500	14 000	
		41.275($1\frac{5}{8}$)	31.75($1\frac{1}{4}$)	1	40 500	60 000	4 100	6 100	9 500	14 000	
31.750($1\frac{1}{4}$)	+0.041 +0.025	44.450($1\frac{3}{4}$)	25.40(1)	1	35 000	51 000	3 550	5 200	8 500	13 000	
		44.450($1\frac{3}{4}$)	31.75($1\frac{1}{4}$)	1	43 500	68 000	4 450	6 950	8 500	13 000	
34.925($1\frac{3}{8}$)	+0.041 +0.025	47.625($1\frac{7}{8}$)	25.40(1)	1	37 000	57 500	3 800	5 850	7 500	11 000	
		47.625($1\frac{7}{8}$)	31.75($1\frac{1}{4}$)	1	46 500	76 500	4 750	7 800	7 500	11 000	
38.100($1\frac{1}{2}$)	+0.041 +0.025	52.388($2\frac{1}{16}$)	25.40(1)	1.5	41 000	61 000	4 150	6 250	7 500	11 000	
		52.388($2\frac{1}{16}$)	31.75($1\frac{1}{4}$)	1.5	51 000	81 500	5 200	8 300	7 500	11 000	
41.275($1\frac{5}{8}$)	+0.041 +0.025	55.562($2\frac{3}{16}$)	25.40(1)	1.5	43 500	68 000	4 450	6 950	6 500	9 500	
		55.562($2\frac{3}{16}$)	31.75($1\frac{1}{4}$)	1.5	54 500	90 500	5 550	9 250	6 500	9 500	
44.450($1\frac{3}{4}$)	+0.041 +0.025	58.738($2\frac{5}{16}$)	25.40(1)	1.5	44 500	72 000	4 550	7 350	6 000	9 000	
		58.738($2\frac{5}{16}$)	31.75($1\frac{1}{4}$)	1.5	55 500	95 500	5 700	9 750	6 000	9 000	
47.625($1\frac{7}{8}$)	+0.041 +0.025	61.912($2\frac{7}{16}$)	31.75($1\frac{1}{4}$)	1.5	59 000	105 000	6 000	10 700	5 500	8 500	
50.800(2)	+0.049 +0.030	65.088($2\frac{9}{16}$)	25.40(1)	1.5	49 500	86 000	5 050	8 800	5 500	8 000	
		65.088($2\frac{9}{16}$)	31.75($1\frac{1}{4}$)	1.5	62 000	114 000	6 300	11 700	5 500	8 000	
57.150($2\frac{1}{4}$)	+0.049 +0.030	76.200(3)	38.10($1\frac{1}{2}$)	1.5	83 500	142 000	8 500	14 500	4 700	7 000	
		76.200(3)	44.45($1\frac{3}{4}$)	1.5	97 000	173 000	9 850	17 600	4 700	7 000	
63.500($2\frac{1}{2}$)	+0.049 +0.030	82.550($3\frac{1}{4}$)	38.10($1\frac{1}{2}$)	2	88 000	158 000	8 950	16 100	4 300	6 500	

Note 1) Allowable minimum chamfer dimension r_s .

2) Max. allowable dimension of radius r_a for corner roundness on shaft/housing.

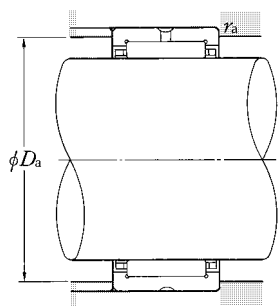

Bearing numbers	Abutment dimensions mm		Mass kg (approx.)
	D_a max	$r_{as}^{2)}$ max	
MR101812	24.5	0.6	0.050
MR101816	24.5	0.6	0.068
MR122012	26.5	1	0.055
MR122016	26.5	1	0.073
MR142212	30	1	0.059
MR142216	30	1	0.082
MR162412	33	1	0.068
MR162416	33	1	0.091
MR182616	36.5	1	0.100
MR182620	36.5	1	0.127
MR202816	39.5	1	0.109
MR202820	39.5	1	0.136
MR223016	42.5	1	0.118
MR223020	42.5	1	0.150
MR243316	46	1.5	0.143
MR243320	46	1.5	0.180
MR263516	49	1.5	0.153
MR263520	49	1.5	0.191
MR283716	52	1.5	0.163
MR283720	52	1.5	0.204
MR303920	55.5	1.5	0.216
MR324116	58.5	1.5	0.183
MR324120	58.5	1.5	0.227
MR364824	69.5	1.5	0.422
MR364828	69.5	1.5	0.493
MR405224	74.5	2	0.472

Inch series Without inner ring

Type MR

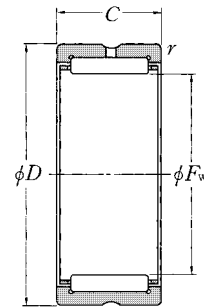

F_w 63.500~184.150mm

Boundary dimensions				Basic load ratings				Limiting speeds		
F_w	mm			dynamic	static	dynamic	static	r/min		
	D	C	$r'_{s \min} 1)$	C_r	C_{or}	C_r	C_{or}	grease	oil	
				N		kgf		(approx.)		
63.500(2 1/2)	+0.049 +0.030	82.550(3 1/4)	44.45(1 3/4)	2	102 000	191 000	10 400	19 500	4 300	6 500
		88.900(3 1/2)	25.40(1)	2	66 000	112 000	6 700	11 400	3 700	5 500
69.850(2 3/4)	+0.049 +0.030	88.900(3 1/2)	38.10(1 1/2)	2	92 000	173 000	9 400	17 600	3 700	5 500
		88.900(3 1/2)	44.45(1 3/4)	2	107 000	209 000	10 900	21 300	3 700	5 500
76.200(3)	+0.049 +0.030	95.250(3 3/4)	38.10(1 1/2)	2	96 000	188 000	9 800	19 100	3 300	5 000
		95.250(3 3/4)	44.45(1 3/4)	2	112 000	227 000	11 400	23 200	3 300	5 000
82.550(3 1/4)	+0.058 +0.036	107.950(4 1/4)	44.45(1 3/4)	2	134 000	240 000	13 600	24 500	3 300	5 000
		107.950(4 1/4)	50.80(2)	2	146 000	268 000	14 900	27 400	3 300	5 000
88.900(3 1/2)	+0.058 +0.036	114.300(4 1/2)	44.45(1 3/4)	2	141 000	264 000	14 400	26 900	3 000	4 500
		114.300(4 1/2)	50.80(2)	2	154 000	295 000	15 700	30 000	3 000	4 500
95.250(3 3/4)	+0.058 +0.036	120.650(4 3/4)	50.80(2)	2.5	162 000	320 000	16 500	32 500	2 800	4 200
101.600(4)	+0.058 +0.036	127.000(5)	50.80(2)	2.5	169 000	345 000	17 200	35 500	2 600	3 900
107.950(4 1/4)	+0.058 +0.036	133.350(5 1/4)	50.80(2)	2.5	172 000	360 000	17 500	37 000	2 500	3 700
114.300(4 1/2)	+0.058 +0.036	152.400(6)	57.15(2 1/4)	2.5	238 000	435 000	24 300	44 500	2 300	3 500
		152.400(6)	63.50(2 1/2)	2.5	260 000	485 000	26 500	49 500	2 300	3 500
127.000(5)	+0.068 +0.043	165.100(6 1/2)	50.80(2)	2.5	227 000	425 000	23 200	43 000	2 100	3 100
		165.100(6 1/2)	57.15(2 1/4)	2.5	250 000	480 000	25 500	49 000	2 100	3 100
		165.100(6 1/2)	63.50(2 1/2)	2.5	273 000	535 000	27 800	54 500	2 100	3 100
139.700(5 1/2)	+0.068 +0.043	177.800(7)	63.50(2 1/2)	2.5	285 000	585 000	29 100	59 500	1 900	2 900
		177.800(7)	76.20(3)	2.5	345 000	740 000	35 000	75 500	1 900	2 900
146.050(5 3/4)	+0.068 +0.043	184.150(7 1/4)	76.20(3)	3	360 000	775 000	36 500	79 000	1 800	2 700
152.400(6)	+0.068 +0.043	190.500(7 1/2)	63.50(2 1/2)	3	310 000	630 000	31 500	64 000	1 700	2 600
		190.500(7 1/2)	76.20(3)	3	375 000	800 000	38 000	81 500	1 700	2 600
165.100(6 1/2)	+0.068 +0.043	203.200(8)	63.50(2 1/2)	3	325 000	680 000	33 000	69 500	1 600	2 400
		203.200(8)	76.20(3)	3	390 000	870 000	39 500	88 500	1 600	2 400
184.150(7 1/4)	+0.079 +0.050	231.775(9 1/8)	76.20(3)	3	435 000	915 000	44 500	93 000	1 500	2 200

Note 1) Allowable minimum chamfer dimension r' .

2) Max. allowable dimension of radius r'_a for corner roundness on shaft/housing.

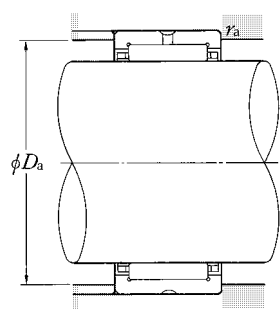

Bearing numbers	Abutment dimensions mm		Mass kg (approx.)
	D_a max	$r_{as}^{2)}$ max	
MR405228	74.5	2	0.533
MR445616	81	2	0.343
MR445624	81	2	0.504
MR445628	81	2	0.580
MR486024	87	2	0.558
MR486028	87	2	0.651
MR526828	100	2	1.02
MR526832	100	2	1.17
MR567228	106.5	2	1.08
MR567232	106.5	2	1.27
MR607632	111.5	2.5	1.28
MR648032	118	2.5	1.29
MR688432	124.5	2.5	1.36
MR729636	143.5	2.5	2.62
MR729640	143.5	2.5	2.91
MR8010432	156	2.5	2.53
MR8010436	156	2.5	2.87
MR8010440	156	2.5	3.19
MR8811240	169	2.5	3.46
MR8811248	169	2.5	4.16
MR9211648	172	3	4.30
MR9612040	177.5	3	3.74
MR9612048	177.5	3	4.49
MR10412840	190	3	4.02
MR10412848	190	3	4.82
MR11614648	219	3	7.36

Inch series
Without inner ring

Type MR

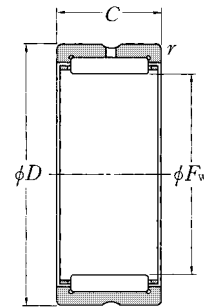

F_w 196.850~234.950mm

Boundary dimensions					Basic load ratings				Limiting speeds	
mm					dynamic	static	dynamic	static	r/min	
F_w	D	C	r_s min ¹⁾		N		kgf		grease	oil
					C_r	C_{or}	C_r	C_{or}	(approx.)	
196.850(7 3/4) ^{+0.079} / _{+0.050}	244.475(9 5/8)	76.20(3)	3		455 000	990 000	46 500	101 000	1 300	2 000
209.550(8 1/4) ^{+0.079} / _{+0.050}	257.175(10 1/8)	76.20(3)	3		475 000	1 060 000	48 500	109 000	1 300	1 900
222.250(8 3/4) ^{+0.079} / _{+0.050}	269.875(10 5/8)	76.20(3)	4		495 000	1 140 000	50 500	116 000	1 200	1 800
234.950(9 1/4) ^{+0.079} / _{+0.050}	282.575(11 1/8)	76.20(3)	4		510 000	1 210 000	52 000	124 000	1 100	1 700

Note 1) Allowable minimum chamfer dimension r .

2) Max. allowable dimension of radius r_a for corner roundness on shaft/housing.

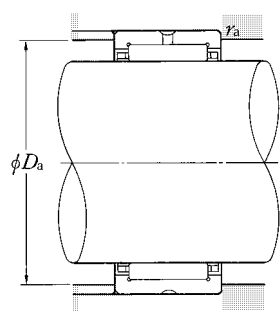

Bearing numbers	Abutment dimensions mm		Mass kg (approx.)
	D_a max	$r_{as}^{2)}$ max	
MR12415448	231.5	3	7.80
MR13216248	244	3	8.36
MR14017048	254	4	8.81
MR14817848	266.5	4	9.27

Inch series With inner ring

Type MR + MI

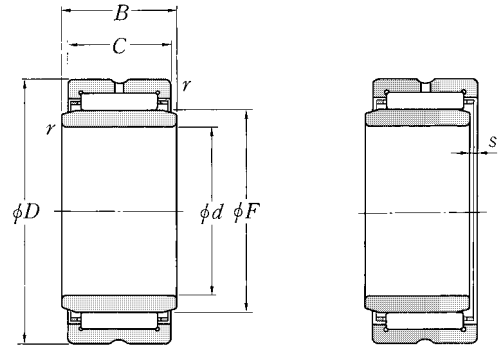

d 9.525~34.925mm

d	Boundary dimensions						Basic load ratings			
	D	B	C	$r_{s \min}^{1)}$	F	$s^{2)}$	dynamic N	static N	dynamic kgf	static kgf
9.525($\frac{3}{8}$)	28.575($1\frac{1}{8}$)	19.30	19.05($\frac{3}{4}$)	0.6	15.875	2	16 700	16 700	1 700	1 700
	28.575($1\frac{1}{8}$)	25.65	25.40(1)	0.6	15.875	3	21 500	23 000	2 190	2 350
12.700($\frac{1}{2}$)	31.750($1\frac{1}{4}$)	19.30	19.05($\frac{3}{4}$)	1	19.050	4	19 500	21 100	1 980	2 150
	31.750($1\frac{1}{4}$)	25.65	25.40(1)	1	19.050	2	25 000	29 100	2 550	2 970
15.875($\frac{5}{8}$)	34.925($1\frac{3}{8}$)	19.30	19.05($\frac{3}{4}$)	1	22.225	1	21 900	25 600	2 240	2 610
	34.925($1\frac{3}{8}$)	25.65	25.40(1)	1	22.225	2	28 200	35 500	2 870	3 600
17.462($1\frac{1}{16}$)	34.925($1\frac{3}{8}$)	19.30	19.05($\frac{3}{4}$)	1	22.225	1.5	21 900	25 600	2 240	2 610
	38.100($1\frac{1}{2}$)	19.30	19.05($\frac{3}{4}$)	1	25.400	1	23 000	28 100	2 340	2 870
19.050($\frac{3}{4}$)	38.100($1\frac{1}{2}$)	25.65	25.40(1)	1	25.400	1.5	29 500	38 500	3 000	3 950
	20.638($1\frac{1}{16}$)	38.100($1\frac{1}{2}$)	25.65	25.40(1)	1	25.400	2	29 500	38 500	3 000
22.225($\frac{7}{8}$)	41.275($1\frac{5}{8}$)	25.65	25.40(1)	1	28.575	1.5	32 500	45 000	3 300	4 600
	41.275($1\frac{5}{8}$)	32.00	31.75($1\frac{1}{4}$)	1	28.575	2	40 500	60 000	4 100	6 100
23.812($1\frac{15}{16}$)	41.275($1\frac{5}{8}$)	25.65	25.40(1)	1	28.575	2	32 500	45 000	3 300	4 600
	41.275($1\frac{5}{8}$)	32.00	31.75($1\frac{1}{4}$)	1	28.575	2	40 500	60 000	4 100	6 100
25.400(1)	44.450($1\frac{3}{4}$)	25.65	25.40(1)	1	31.750	1.5	35 000	51 000	3 550	5 200
	44.450($1\frac{3}{4}$)	32.00	31.75($1\frac{1}{4}$)	1	31.750	2	43 500	68 000	4 450	6 950
28.575($1\frac{1}{8}$)	47.625($1\frac{7}{8}$)	25.65	25.40(1)	1	34.925	3	37 000	57 500	3 800	5 850
	47.625($1\frac{7}{8}$)	32.00	31.75($1\frac{1}{4}$)	1	34.925	2	46 500	76 500	4 750	7 800
30.162($1\frac{3}{16}$)	52.388($2\frac{1}{16}$)	32.00	31.75($1\frac{1}{4}$)	1	38.100	2	51 000	81 500	5 200	8 300
31.750($1\frac{1}{4}$)	52.388($2\frac{1}{16}$)	25.65	25.40(1)	1.5	38.100	0.5	41 000	61 000	4 150	6 250
	52.388($2\frac{1}{16}$)	32.00	31.75($1\frac{1}{4}$)	1.5	38.100	1	51 000	81 500	5 200	8 300
33.338($1\frac{5}{16}$)	55.562($2\frac{3}{16}$)	25.65	25.40(1)	1.5	41.275	0.5	43 500	68 000	4 450	6 950
	55.562($2\frac{3}{16}$)	32.00	31.75($1\frac{1}{4}$)	1.5	41.275	1	54 500	90 500	5 550	9 250
34.925($1\frac{3}{8}$)	55.562($2\frac{3}{16}$)	32.00	31.75($1\frac{1}{4}$)	1.5	41.275	0.5	54 500	90 500	5 550	9 250
	58.738($2\frac{5}{16}$)	25.65	25.40(1)	1.5	44.450	0.5	44 500	72 000	4 550	7 350
	58.738($2\frac{5}{16}$)	32.00	31.75($1\frac{1}{4}$)	1.5	44.450	1	55 500	95 500	5 700	9 750

Note 1) Allowable minimum chamfer dimension r . 2) Allowable axial stroking value of inner ring against outer ring.
2) Max. allowable dimension of radius r_a for corner roundness on shaft/housing.

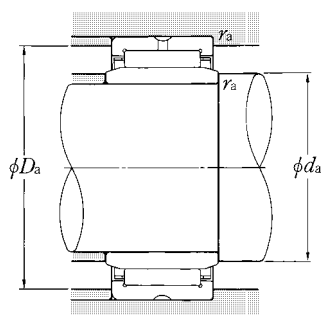

Limiting speeds		Bearing numbers	Abutment dimensions			Mass kg (approx.)
min ⁻¹ grease	oil		d_a min	mm D_a max	r_{as} ³⁾ max	
17 000	25 000	MR101812 + MI-061012	13.5	24.5	0.6	0.069
17 000	25 000	MR101816 + MI-061016	13.5	24.5	0.6	0.093
14 000	21 000	MR122012 + MI-081212	17.5	26.5	1	0.079
14 000	21 000	MR122016 + MI-081216	17.5	26.5	1	0.105
12 000	18 000	MR142212 + MI-101412	21	30	1	0.086
12 000	18 000	MR142216 + MI-101416	21	30	1	0.118
12 000	18 000	MR142212 + MI-111412	21	30	1	0.079
11 000	16 000	MR162412 + MI-121612	24	33	1	0.102
11 000	16 000	MR162416 + MI-121616	24	33	1	0.136
11 000	16 000	MR162416 + MI-131616	24	33	1	0.125
9 500	14 000	MR182616 + MI-141816	27	36.5	1	0.152
9 500	14 000	MR182620 + MI-141820	27	36.5	1	0.193
9 500	14 000	MR182616 + MI-151816	27	36.5	1	0.139
9 500	14 000	MR182620 + MI-151820	27	36.5	1	0.176
8 500	13 000	MR202816 + MI-162016	30.5	39.5	1	0.161
8 500	13 000	MR202820 + MI-162020	30.5	39.5	1	0.201
7 500	11 000	MR223016 + MI-182216	33.5	42.5	1	0.181
7 500	11 000	MR223020 + MI-182220	33.5	42.5	1	0.229
7 500	11 000	MR243320 + MI-192420	35	46	1.5	0.286
7 500	11 000	MR243316 + MI-202416	37	46	1.5	0.230
7 500	11 000	MR243320 + MI-202420	37	46	1.5	0.285
6 500	9 500	MR263516 + MI-212616	40	49	1.5	0.257
6 500	9 500	MR263520 + MI-212620	40	49	1.5	0.325
6 500	9 500	MR263520 + MI-222620	40	49	1.5	0.286
6 000	9 000	MR283716 + MI-222816	41.5	52	1.5	0.294
6 000	9 000	MR283720 + MI-222820	41.5	52	1.5	0.364

Inch series With inner ring

Type MR + MI

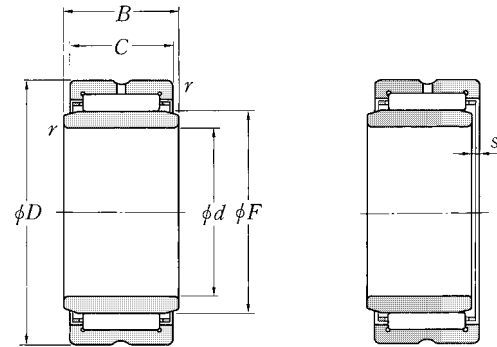

d 36.512~66.675mm

d	Boundary dimensions						Basic load ratings			
	D	B	C	$r_{s \min}^{1)}$	F'	$s^{2)}$	dynamic N	static N	dynamic kgf	static kgf
36.512(1 1/16)	58.738(2 5/16)	25.65	25.40(1)	1.5	44.450	0.5	44 500	72 000	4 550	7 350
	58.738(2 5/16)	32.00	31.75(1 1/4)	1.5	44.450	0.5	55 500	95 500	5 700	9 750
38.100(1 1/2)	58.738(2 5/16)	25.65	25.40(1)	1.5	44.450	0.5	44 500	72 000	4 550	7 350
	58.738(2 5/16)	32.00	31.75(1 1/4)	1.5	44.450	0.5	55 500	95 500	5 700	9 750
39.688(1 9/16)	65.088(2 9/16)	32.00	31.75(1 1/4)	1.5	50.800	0.5	62 000	114 000	6 300	11 700
	61.912(2 7/16)	32.00	31.75(1 1/4)	1.5	47.625	1	59 000	105 000	6 000	10 700
41.275(1 5/8)	65.088(2 9/16)	32.00	31.75(1 1/4)	1.5	50.800	0.5	62 000	114 000	6 300	11 700
	65.088(2 9/16)	25.65	25.40(1)	1.5	50.800	1	49 500	86 000	5 050	8 800
42.682(1 11/16)	65.088(2 9/16)	32.00	31.75(1 1/4)	1.5	50.800	0.5	62 000	114 000	6 300	11 700
	65.088(2 9/16)	25.65	25.40(1)	1.5	50.800	0.5	49 500	86 000	5 050	8 800
44.450(1 3/4)	76.200(3)	38.35	38.10(1 1/2)	1.5	57.150	3.5	83 500	142 000	8 500	14 500
	76.200(3)	44.70	44.45(1 3/4)	1.5	57.150	3.5	97 000	173 000	9 850	17 600
49.212(1 15/16)	82.550(3 1/4)	38.35	38.10(1 1/2)	2	63.500	1.5	88 000	158 000	8 950	16 100
	82.550(3 1/4)	44.70	44.45(1 3/4)	2	63.500	2	102 000	191 000	10 400	19 500
50.800(2)	82.550(3 1/4)	38.35	25.40(1)	2	63.500	2.5	88 000	158 000	8 950	16 100
	82.550(3 1/4)	44.70	44.45(1 3/4)	2	63.500	3	102 000	191 000	10 400	19 500
55.562(2 3/16)	88.900(3 1/2)	44.70	44.45(1 3/4)	2	69.850	1.5	107 000	209 000	10 900	21 300
	88.900(3 1/2)	25.65	25.40(1)	2	69.850	0.5	66 000	112 000	6 700	11 400
57.150(2 1/4)	88.900(3 1/2)	38.35	38.10(1 1/2)	2	69.850	2.5	92 000	173 000	9 400	17 600
	88.900(3 1/2)	44.70	44.45(1 3/4)	2	69.850	3	107 000	209 000	10 900	21 300
60.325(2 3/8)	95.250(3 3/4)	44.70	44.45(1 3/4)	2	76.200	1.5	112 000	227 000	11 400	23 200
63.500(5/2)	95.250(3 3/4)	38.35	38.10(1 1/2)	2	76.200	2.5	96 000	188 000	9 800	19 100
	95.250(3 3/4)	44.70	44.45(1 3/4)	2	76.200	3	112 000	227 000	11 400	23 200
66.675(2 5/8)	107.950(4 1/4)	44.70	44.45(1 3/4)	2	82.550	3	134 000	240 000	13 600	24 500
	107.950(4 1/4)	51.05	50.80(2)	2	82.550	5.5	146 000	268 000	14 900	27 400

Note 1) Allowable minimum chamfer dimension r . 2) Allowable axial stroking value of inner ring against outer ring.
2) Max. allowable dimension of radius r_a for corner roundness on shaft/housing.

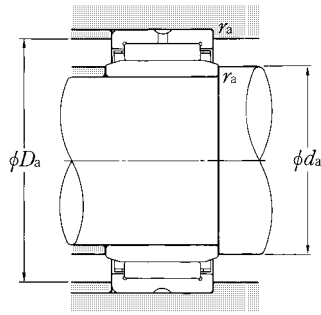

Limiting speeds		Bearing numbers	Abutment dimensions			Mass kg (approx.)
grease	oil		d_a min	mm D_a max	r_{as} ³⁾ max	
6 000	9 000	MR283716 + MI-232816	43	52	1.5	0.264
6 000	9 000	MR283720 + MI-232820	43	52	1.5	0.330
6 000	9 000	MR283716 + MI-242816	43	52	1.5	0.246
6 000	9 000	MR283720 + MI-242820	43	52	1.5	0.307
5 500	8 000	MR324120 + MI-243220	44.5	58.5	1.5	0.448
5 500	8 500	MR303920 + MI-253020	46.5	55.5	1.5	0.368
5 500	8 000	MR324120 + MI-253220	46	58.5	1.5	0.424
5 500	8 000	MR324116 + MI-263216	48	58.5	1.5	0.317
5 500	8 000	MR324120 + MI-263220	48	58.5	1.5	0.402
5 500	8 000	MR324116 + MI-273216	49.5	58.5	1.5	0.300
5 500	8 000	MR324120 + MI-273220	49.5	58.5	1.5	0.373
4 700	7 000	MR364824 + MI-283624	51	69.5	1.5	0.732
4 700	7 000	MR364828 + MI-283628	51	69.5	1.5	0.853
4 300	6 500	MR405224 + MI-314024	56	74.5	2	0.848
4 300	6 500	MR405228 + MI-314028	56	74.5	2	0.975
4 300	6 500	MR405224 + MI-324024	59	74.5	2	0.812
4 300	6 500	MR405228 + MI-324028	59	74.5	2	0.923
3 700	5 500	MR445628 + MI-354428	63.5	81	2	1.07
3 700	5 500	MR445616 + MI-364416	65	81	2	0.594
3 700	5 500	MR445624 + MI-364424	65	81	2	0.884
3 700	5 500	MR445628 + MI-364428	65	81	2	1.02
3 300	5 000	MR486028 + MI-384828	68	87	2	1.25
3 300	5 000	MR486024 + MI-404824	71.5	87	2	0.978
3 300	5 000	MR486028 + MI-404828	71.5	87	2	1.14
3 300	5 000	MR526828 + MI-425228	74.5	100	2	1.67
3 300	5 000	MR526832 + MI-425232	74.5	100	2	1.92

Inch series With inner ring

Type MR + MI

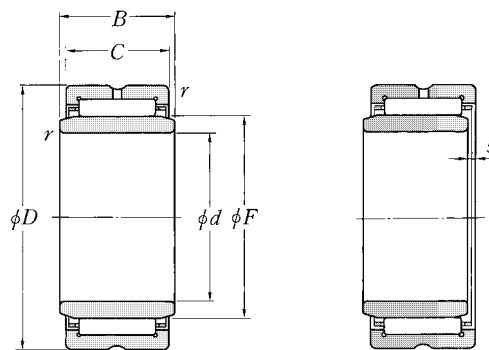

d 69.850~127.000mm

Boundary dimensions							Basic load ratings			
mm ($\frac{1}{25.4}$ mm)							dynamic	static	dynamic	static
d	D	B	C	$r_{s \min}^{1)}$	F'	$s^{2)}$	C_r	C_{or}	C_r	C_{or}
							N		kgf	
69.850(2 $\frac{3}{4}$)	107.950(4 $\frac{1}{4}$)	44.70	44.45(1 $\frac{3}{4}$)	2	82.550	1.5	134 000	240 000	13 600	24 500
	107.950(4 $\frac{1}{4}$)	51.05	50.80(2)	2	82.550	3	146 000	268 000	14 900	27 400
74.612(2 $\frac{15}{16}$)	114.300(4 $\frac{1}{2}$)	51.05	50.80(2)	2	88.900	3	154 000	295 000	15 700	30 000
76.200(3)	114.300(4 $\frac{1}{2}$)	44.70	44.45(1 $\frac{3}{4}$)	2	88.900	3	141 000	264 000	14 400	26 900
	114.300(4 $\frac{1}{2}$)	51.05	50.80(2)	2	88.900	5.5	154 000	295 000	15 700	30 000
79.375(3 $\frac{1}{8}$)	120.650(4 $\frac{3}{4}$)	51.05	50.80(2)	2.5	95.250	5.5	162 000	320 000	16 500	32 500
82.550(3 $\frac{1}{4}$)	120.650(4 $\frac{3}{4}$)	51.05	50.80(2)	2.5	95.250	2.5	162 000	320 000	16 500	32 500
	127.000(5)	51.05	50.80(2)	2.5	101.600	2.5	169 000	345 000	17 200	35 500
85.725(3 $\frac{3}{8}$)	127.000(5)	51.05	50.80(2)	2.5	101.600	4.5	169 000	345 000	17 200	35 500
88.900(3 $\frac{1}{2}$)	127.000(5)	51.05	50.80(2)	2.5	101.600	2.5	169 000	345 000	17 200	35 500
	133.350(5 $\frac{1}{4}$)	51.05	50.80(2)	2.5	107.950	2.5	172 000	360 000	17 500	37 000
92.075(3 $\frac{5}{8}$)	133.350(5 $\frac{1}{4}$)	51.05	50.80(2)	2.5	107.950	4.5	172 000	360 000	17 500	37 000
	133.350(5 $\frac{1}{4}$)	51.05	50.80(2)	2.5	107.950	2.5	172 000	360 000	17 500	37 000
	152.400(6)	57.40	57.15(2 $\frac{1}{4}$)	2.5	114.300	3	238 000	435 000	24 300	44 500
95.250(3 $\frac{3}{4}$)	152.400(6)	63.88	63.50(2 $\frac{1}{2}$)	2.5	114.300	4	260 000	485 000	26 500	49 500
	152.400(6)	57.40	57.15(2 $\frac{1}{4}$)	2.5	114.300	5.5	238 000	435 000	24 300	44 500
98.425(3 $\frac{7}{8}$)	152.400(6)	63.88	63.50(2 $\frac{1}{2}$)	2.5	114.300	7	260 000	485 000	26 500	49 500
	165.100(6 $\frac{1}{2}$)	51.05	50.80(2)	2.5	127.000	2.5	227 000	425 000	23 200	43 000
101.600(4)	165.100(6 $\frac{1}{2}$)	57.40	57.15(2 $\frac{1}{4}$)	2.5	127.000	5.5	250 000	480 000	25 500	49 000
	165.100(6 $\frac{1}{2}$)	63.88	57.15(2 $\frac{1}{4}$)	2.5	127.000	7	273 000	535 000	27 800	54 500
	165.100(6 $\frac{1}{2}$)	57.40	57.15(2 $\frac{1}{4}$)	2.5	127.000	3	250 000	480 000	25 500	49 000
107.950(4 $\frac{1}{4}$)	177.800(7)	63.88	63.50(2 $\frac{1}{2}$)	2.5	139.700	5.5	285 000	585 000	29 100	59 500
	177.800(7)	76.58	76.20(3)	2.5	139.700	7	345 000	740 000	35 000	75 500
120.650(4 $\frac{3}{4}$)	184.150(7 $\frac{1}{4}$)	82.55	76.20(3)	3	146.050	3	360 000	775 000	36 500	79 000
127.000(5)	190.500(7 $\frac{1}{2}$)	63.88	63.50(2 $\frac{1}{2}$)	3	152.400	7	310 000	630 000	31 500	64 000
	190.500(7 $\frac{1}{2}$)	76.58	76.20(3)	3	152.400	5.5	375 000	800 000	38 000	81 500

Note 1) Allowable minimum chamfer dimension r . 2) Allowable axial stroking value of inner ring against outer ring.
2) Max. allowable dimension of radius r_a for corner roundness on shaft/housing.

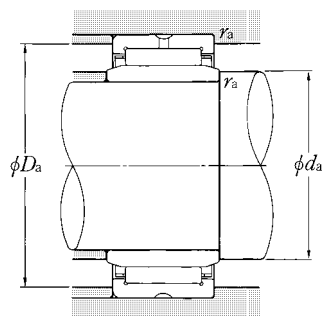

Limiting speeds		Bearing numbers	Abutment dimensions			Mass kg (approx.)
grease	oil		d_a min	mm D_a max	r_{as} ³⁾ max	
3 300	5 000	MR526828 + MI-445228	78	100	2	1.55
3 300	5 000	MR526832 + MI-445232	78	100	2	1.77
3 000	4 500	MR567232 + MI-475632	83	106.5	2	2.00
3 000	4 500	MR567228 + MI-485628	84	106.5	2	1.65
3 000	4 500	MR567232 + MI-485632	84	106.5	2	1.92
2 800	4 200	MR607632 + MI-506032	88.5	111.5	2.5	2.15
2 800	4 200	MR607632 + MI-526032	91.5	111.5	2.5	1.99
2 600	3 900	MR648032 + MI-526432	91.5	118	2.5	2.39
2 600	3 900	MR648032 + MI-546432	94.5	118	2.5	2.22
2 600	3 900	MR648032 + MI-566432	98	118	2.5	2.05
2 500	3 700	MR688432 + MI-566832	98	124.5	2.5	2.53
2 500	3 700	MR688432 + MI-586832	101	124.5	2.5	2.36
2 500	3 700	MR688432 + MI-606832	104.5	124.5	2.5	2.17
2 300	3 500	MR729636 + MI-607236	104.5	143.5	2.5	4.02
2 300	3 500	MR729640 + MI-607240	104.5	143.5	2.5	4.47
2 300	3 500	MR729636 + MI-627236	107.5	143.5	2.5	3.77
2 300	3 500	MR729640 + MI-627240	107.5	143.5	2.5	4.19
2 100	3 100	MR8010432 + MI-648032	110.5	156	2.5	3.60
2 100	3 100	MR8010436 + MI-648036	110.5	156	2.5	4.92
2 100	3 100	MR8010440 + MI-648040	110.5	156	2.5	5.47
2 100	3 100	MR8010436 + MI-688036	117	156	2.5	4.44
1 900	2 900	MR8811240 + MI-728840	123.5	169	2.5	6.04
1 900	2 900	MR8811248 + MI-728848	123.5	169	2.5	7.26
1 800	2 700	MR9211648 + MI-769248	132	172	3	7.48
1 700	2 600	MR9612040 + MI-809640	140	177.5	3	6.54
1 700	2 600	MR9612048 + MI-809648	140	177.5	3	7.84

Inch series
With inner ring

Type MR + MI

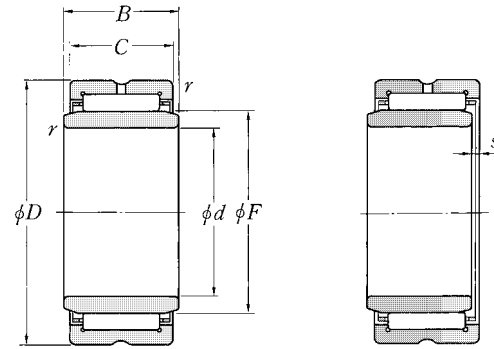

d 139.700~203.200mm

d	Boundary dimensions						Basic load ratings			
	D	B	C	$r_{s \min}^{1)}$	F	$s^{2)}$	dynamic N	static N	dynamic kgf	static kgf
139.700(5 1/2)	203.200(8)	63.88	63.50(2 1/2)	3	165.100	6	325 000	680 000	33 000	69 500
	203.200(8)	76.58	76.20(3)	3	165.100	5.5	390 000	870 000	39 500	88 500
152.400(6)	231.775(9 1/8)	76.58	76.20(3)	3	184.150	8.5	435 000	915 000	44 500	93 000
165.100(6 1/2)	244.475(9 5/8)	76.58	76.20(3)	3	196.850	8.5	455 000	990 000	46 500	101 000
177.800(7)	257.175(10 1/8)	76.58	76.20(3)	3	209.550	8.5	475 000	1 060 000	48 500	109 000
190.500(7 1/2)	269.875(10 5/8)	76.58	76.20(3)	4	222.250	7	495 000	1 140 000	50 500	116 000
203.200(8)	282.575(11 1/8)	76.58	76.20(3)	4	234.950	7	510 000	1 210 000	52 000	124 000

Note 1) Allowable minimum chamfer dimension r . 2) Allowable axial stroking value of inner ring against outer ring.
2) Max. allowable dimension of radius r_a for corner roundness on shaft/housing.

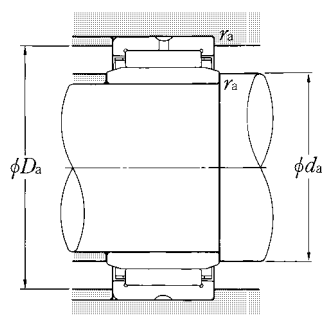

Limiting speeds		Bearing numbers	Abutment dimensions			Mass kg (approx.)
min ⁻¹ grease	oil		d_a min	mm D_a max	r_{as} ³⁾ max	
1 600	2 400	MR10412840 + MI-8810440	152.5	190	3	6.86
1 600	2 400	MR10412848 + MI-8810448	152.5	190	3	8.22
1 500	2 200	MR11614648 + MI-9611648	165.5	219	3	12.2
1 300	2 000	MR12415448 + MI-10412448	178	231.5	3	13.1
1 300	1 900	MR13216248 + MI-11213248	191	244	3	14.0
1 200	1 800	MR14017048 + MI-12014048	206.5	254	4	15.0
1 100	1 700	MR14817848 + MI-12814848	219	266.5	4	15.8

Without inner ring

Type RNA49·L
Type RNA49·LL

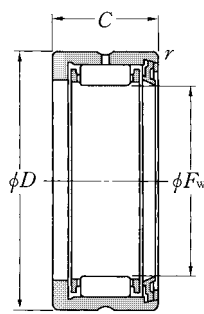

Type RNA49·L
(With single seal)

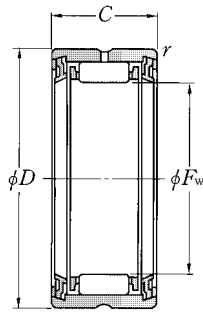

Type RNA49·LL
(With double seal)

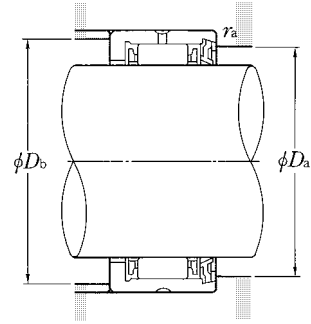

F_w 14~58mm

Boundary dimensions				Basic load ratings				Limiting speeds min ⁻¹ grease	Bearing numbers		Abutment dimensions			Mass kg (approx.)	
mm				dynamic	static	dynamic	static		Type	Type	D_a	D_b	$r_{as}^{2)}$		
F_w	D	C	$r_s \min^{1)}$	C_r	C_{or}	C_r	C_{or}	RNA49·L	RNA49·LL	max	max	max			
14	$+0.027$ $+0.016$	22	13	0.3	7 200	8 500	735	865	10 000	RNA4900L/3AS	RNA4900LL/3AS	16	20	0.3	0.016
16	$+0.027$ $+0.016$	24	13	0.3	7 750	9 700	795	990	10 000	RNA4901L/3AS	RNA4901LL/3AS	18	22	0.3	0.018
20	$+0.033$ $+0.020$	28	13	0.3	8 300	11 200	845	1 150	10 000	RNA4902L/3AS	RNA4902LL/3AS	22	26	0.3	0.022
22	$+0.033$ $+0.020$	30	13	0.3	8 500	11 900	865	1 220	9 000	RNA4903L/3AS	RNA4903LL/3AS	24	28	0.3	0.022
25	$+0.033$ $+0.020$	37	17	0.3	15 200	19 900	1 550	2 030	8 000	RNA4904L/3AS	RNA4904LL/3AS	28	35	0.3	0.055
30	$+0.033$ $+0.020$	42	17	0.3	16 000	22 600	1 640	2 300	6 500	RNA4905L/3AS	RNA4905LL/3AS	33	40	0.3	0.063
35	$+0.041$ $+0.025$	47	17	0.3	18 000	27 400	1 830	2 800	5 500	RNA4906L/3AS	RNA4906LL/3AS	38	45	0.3	0.072
42	$+0.041$ $+0.025$	55	20	0.6	22 700	39 500	2 320	4 000	4 800	RNA4907L/3AS	RNA4907LL/3AS	45	51	0.6	0.113
48	$+0.041$ $+0.025$	62	22	0.6	27 800	53 500	2 830	5 450	4 200	RNA4908L/3AS	RNA4908LL/3AS	51	58	0.6	0.154
52	$+0.049$ $+0.030$	68	22	0.6	28 600	57 000	2 920	5 800	3 800	RNA4909L/3AS	RNA4909LL/3AS	55	64	0.6	0.157
58	$+0.049$ $+0.030$	72	22	0.6	30 500	64 000	3 100	6 500	3 400	RNA4910L/3AS	RNA4910LL/3AS	61	68	0.6	0.160

Note 1) Allowable minimum chamfer dimension r .

2) Max. allowable dimension of radius r_a for corner roundness on shaft/housing.

With inner ring

Type NA49··L
Type NA49··LL

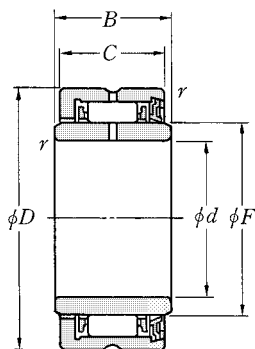

Type NA49··L
(With single seal)

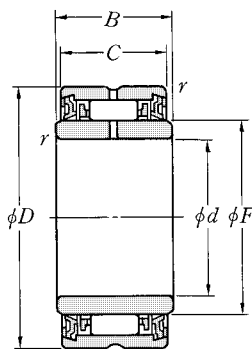

Type NA49··LL
(With double seal)

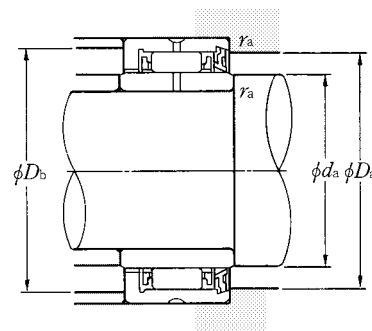

d 10~50mm

Boundary dimensions						Basic load ratings				Limiting speeds min ⁻¹ grease	Bearing numbers		Abutment dimensions				Mass kg (approx.)
mm						dynamic N	static N	dynamic kgf	static kgf		Type NA49··L	Type RNA49··LL	d _a min	D _a max	D _b max	r _{as} ²⁾ max	
d	D	B	C	r _{s min} ¹⁾	F	C _r	C _{or}	C _r	C _{or}								
10	22	14	13	0.3	14	7 200	8 500	735	865	10 000	NA4900L/3AS	NA4900LL/3AS	12	16	20	0.3	0.025
12	24	14	13	0.3	16	7 750	9 700	795	990	10 000	NA4901L/3AS	NA4901LL/3AS	14	18	22	0.3	0.028
15	28	14	13	0.3	20	8 300	11 200	845	1 150	10 000	NA4902L/3AS	NA4902LL/3AS	17	22	26	0.3	0.036
17	30	14	13	0.3	22	8 500	11 900	865	1 220	9 000	NA4903L/3AS	NA4903LL/3AS	19	24	28	0.3	0.039
20	37	18	17	0.3	25	15 200	19 900	1 550	2 030	8 000	NA4904L/3AS	NA4904LL/3AS	22	28	35	0.3	0.080
25	42	18	17	0.3	30	16 000	22 600	1 640	2 300	6 500	NA4905L/3AS	NA4905LL/3AS	27	33	40	0.3	0.093
30	47	18	17	0.3	35	18 000	27 400	1 830	2 800	5 500	NA4906L/3AS	NA4906LL/3AS	32	38	45	0.3	0.107
35	55	21	20	0.6	42	22 700	39 500	2 320	4 000	4 800	NA4907L/3AS	NA4907LL/3AS	39	45	51	0.6	0.175
40	62	23	22	0.6	48	27 800	53 500	2 830	5 450	4 200	NA4908L/3AS	NA4908LL/3AS	44	51	58	0.6	0.252
45	68	23	22	0.6	52	28 600	57 000	2 920	5 800	3 800	NA4909L/3AS	NA4909LL/3AS	49	55	64	0.6	0.290
50	72	23	22	0.6	58	30 500	64 000	3 100	6 500	3 400	NA4910L/3AS	NA4910LL/3AS	54	61	68	0.6	0.295

Note 1) Allowable minimum chamfer dimension r.

2) Max. allowable dimension of radius r_a for corner roundness on shaft/housing.