

SKF insert bearing units UC range



SKF UC range, designed for JIS* equipment

You need a robust and reliable insert bearing unit solution, one that's easy to install, simple to order and improves productivity. SKF now offers a product that matches your operational and application requirements.

At SKF, we have developed a range of insert bearing units, called "UC range", designed to be interchangeable with JIS* equipment. These SKF UC bearing units are designed with a set screw locking feature, to operate in environments where systemic vibrations are characteristic application conditions.

* JIS: Japanese Industrial Standards

Easy to order, easy to replace

You want a solution that makes your life easy – A solution with the same boundary dimensions, housing configurations and part numbers as many other products available today on the market.

The SKF insert bearing units - UC range achieves this and more. It's an interchangeable solution with JIS* housings available today on the market with an enhanced locking design insert bearing that helps provide more productive, more reliable, and smoother running rotating equipment.

What's more, no modification of your machine is needed. The dimensions meet most of the current UC designated bearing unit fitting requirements, enhancing interchangeability. And whatever product you need, with SKF you know it will be easy to obtain and straightforward to install.



Applications include

- Parcel and baggage handling conveyors
- Material handling conveyors
- Food process machinery
- Packaging equipment
- HVAC equipment
- Agriculture machinery
- Construction machinery
- Textile machinery
- Fitness equipment
- Escalators
- Metals industry

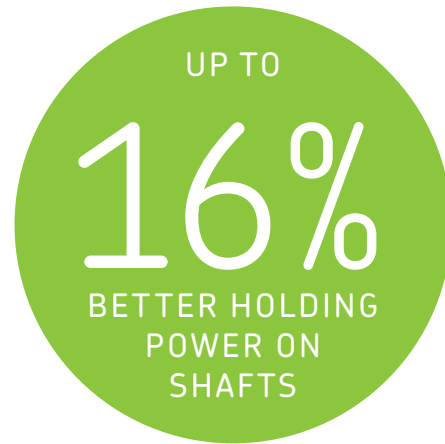
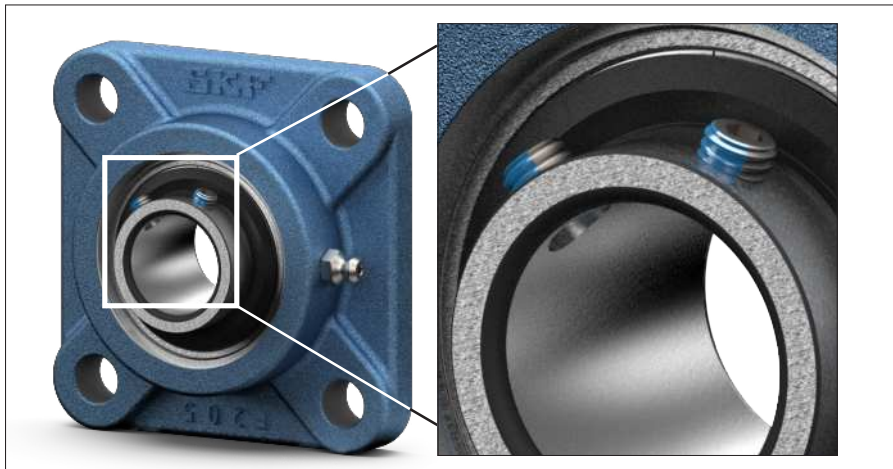

Combining JIS* compatibility with SKF reliability

With over 100 years of experience, SKF understands machine and plant productivity and the need to deliver high rotating equipment performance.

The SKF UC range has been designed to provide reliable performance as well and reduce machine downtime. It includes specific features that can make the difference in your equipment.

An enhanced set screw locking system

One of the reasons for failure in a low speed, highly loaded conveyor applications is machine vibration loosening the locking systems.

SKF has overcome this problem by using an enhanced set screw locking design. At its heart is a nylon patch that creates extra resistance to screw loosening. A simple, solution which eliminates the labour associated with the use of messy liquid locking compounds that have no removal or reinstallation options.

The locking device on the SKF UC range increases the axial holding power by up to 16% (→ **Diagram 1**), so there is greater grip between the shaft and bearing. This is a big advantage for units operating in systemic vibrating applications, such as conveyors.

A solid base and solid feet for increased cleanliness and better bearing unit support

The solid base design of SKF insert bearing units – UC range provides a cleaner surface with less contaminant ingress for improved bearing unit support, especially the often heavily contaminated conveyor operating environment. A solid base design is now standard on our two bolt flanged housings as well as a solid feet on our pillow block housings (→ **fig. 1**). This limits the opportunity for dirt to collect underneath the housing support – another step forward for better bearing unit hygiene.

Diagram 1

Shaft holding power [kN]

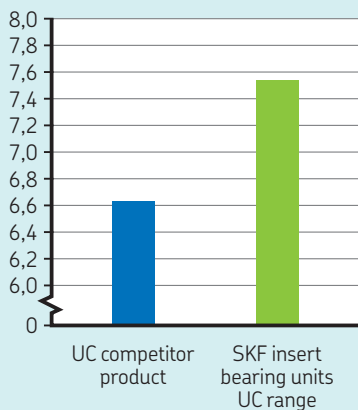

Note: testing results based on two 1/4 in shaft set screws, individual results may vary depending on shaft material and hardness, and other factors.

Fig. 1





Please note that end covers are not included with the SKF insert bearing units and must be ordered separately.

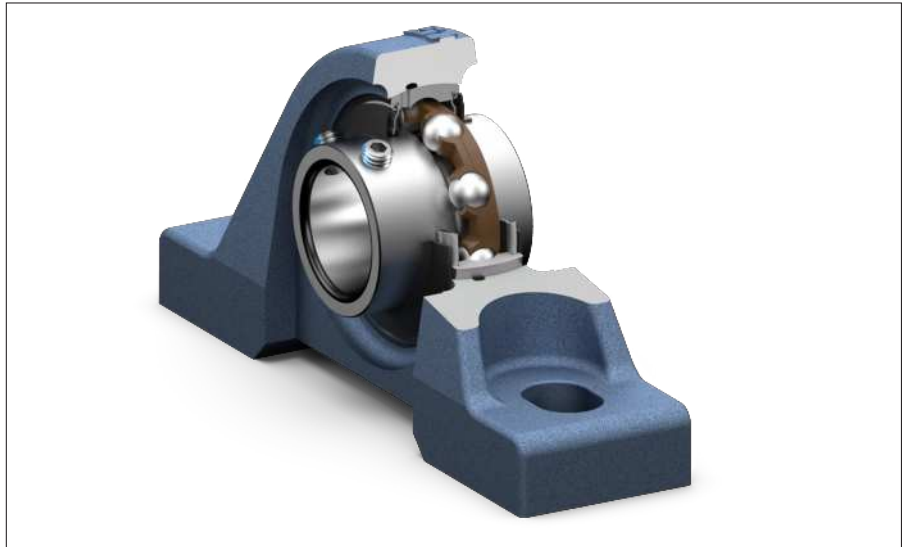

Optional end covers for flanged and take-up housings

To comply with health and safety regulations, SKF UC bearing units with flanged and take-up housings are available with polypropylene end covers. SKF offers these end covers as high availability option.

SKF high-quality grease

Poor lubrication accounts for over 36% of premature bearing failures. In fact, most low speed applications fail due to lubrication related issues, not necessarily due to bearing fatigue. Provided recommended maintenance

intervals are followed, SKF high-quality grease helps bearings achieve expected service life as the SKF range of lubricants are designed to perform under real conditions (→ Table 1).

Sealing system

The standard seal for SKF insert bearing units – UC range is the rugged integral seal protected with an additional flinger to help exclude contaminants. The integral seal consists of a pressed sheet steel washer with a sealing lip made of NBR bonded to its inner surface. The coated non-contact sheet steel washer forms a narrow gap with the cylindrical surface of the inner ring protecting the

land-riding seal against contaminants. Enhancing the seal's effectiveness are externally applied coated flingers.

Other sealing solutions are available for extremely contaminated operating environments. Please contact the SKF application engineering service for more information.

Benefit from the SKF's global distribution network

Finding replacement parts can sometimes be a challenge. SKF is well positioned to bring you the right support and the right parts, no matter where your application is based. We have 17 000 distribution locations in over 130 countries around the globe.

Table 1

Lubricating greases

Technical specification	Grease fills in standard insert bearings standard insert bearing units
Thickener	Lithium-calcium soap
Base oil	Mineral oil
Colour	Yellowish brown
Temperature range [°C] (continuous operation)	-30 to +120 ¹⁾
Kinematic viscosity [mm ² /s]	190/15
Consistency (to NLGI scale)	2
Other	Long life grease

¹⁾ The temperature range for reliable operation in accordance with the SKF traffic light concept is between 10 and 120 °C.

The advantages for you at a glance

- Interchangeable with JIS* housings
- A more secure locking system in applications where systemic vibrations occur
- Widely available throughout SKF's global distribution network resulting in shorter lead times

* JIS: Japanese Industrial Standards

Designations

The complete designation for the SKF insert bearing units – UC range consists of:

- Prefixes, identifying insert bearing or housing series
- Figures, identifying the size
- Suffixes, identifying design and variants

More details about the basic designations and the supplementary designations can be obtained from the table **Designation system**.

Designation system

Examples:	UCP 205	UC	P	2	05	
	UCF 205-15	UC	F	2	05-15	
	UCFL 204B	UC	FL	2	04	B
	T 215	UC	T	2	15	
	UC 312	UC		3	12	

Bearing series

UC Insert bearing, cylindrical bore with set screws

Housing type

P	Pillow block unit
F	Flanged unit, square 4-bolt flange
FL	Flanged unit, oval 2-bolt flange
FC	Flanged unit, round 4-bolt flange
FS	Flanged unit, square piloted 4-bolt flange ²⁾
T	Take-up unit for linear motion ¹⁾
FB	Flanged unit, 3-bolt flange ¹⁾
PA	Tapped base pillow block unit ¹⁾
LP	Pillow block unit, lower center height ²⁾
PH	Pillow block unit, high center height ²⁾
IP	Thick pillow block unit ²⁾
FA	Take-up unit for swivel motion ²⁾
C	Cartridge unit ²⁾
HA	Hanger unit ²⁾

Dimension series

2	Normal series
3	Heavy duty series ¹⁾

Bore diameter

04	For metric shaft 20 mm
15	75 mm
	For inch shaft ¹⁾ Two-digit number follows the basic metric bearing size and is separated from this by a hyphen; it is the number of sixteenths ($\frac{1}{16}$) of an inch
05-15	$\frac{15}{16}$ in = 23,813 mm

Suffixes

B	Revise mounting bearing in housing
Z	With inch threaded attaching holes when metric is the standard
J	Pressed steel cage (omitted in size above 210 as pressed steel cage is standard feature)
AH	Air handling execution
VZ811	With groove for mounting end cover (omitted in some flanged housing types as a standard design)

¹⁾ Planned launch mid 2017. Contact your local SKF representative for more information.

²⁾ Planned launch mid 2018. Contact your local SKF representative for more information.

Insert bearings with set screws, metric shafts

d 20 – 100 mm

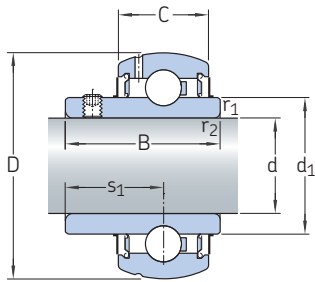

Polymer cage for size 204 to 210

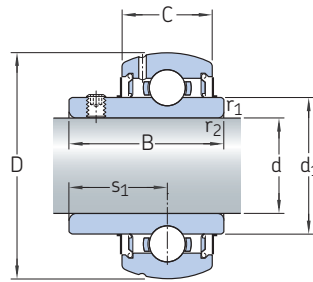

Pressed steel cage for size 211 and above

Dimensions							Basic load ratings		Fatigue load limit	Limiting speed with shaft tolerance h6	Mass	Designation
d	D	B	C	d ₁	s ₁	r _{1,2} min.	C	C ₀	P _u	r/min	kg	–
mm							kN		kN			
20	47	31	15	28,7	18,3	1	12,7	6,7	0,3	6 500	0,15	UC 204
25	52	34	15	33,7	19,7	1	14,0	7,8	0,3	5 850	0,19	UC 205
30	62	38,1	18	39,8	22,2	1	19,5	11,4	0,5	5 000	0,30	UC 206
	72	43	21	44,8	26	2	26,5	15,0	0,64	5 300	0,54	UC 306
35	72	42,9	19	46,8	25,4	1,1	25,5	15,3	0,7	4 300	0,46	UC 207
	80	48	23	50,4	29	2,5	33,2	19,3	0,815	4 700	0,71	UC 307
40	80	49,2	22	52,5	30,2	1,1	32,5	20,0	0,9	3 750	0,61	UC 208
	90	52	25	56,5	33	2,5	41,0	24,0	1,02	4 200	0,96	UC 308
45	85	49,2	22	57,3	30,2	1,1	32,5	20,4	0,9	3 400	0,67	UC 209
	100	57	29	63	35	2,5	52,7	32,0	1,34	3 750	1,30	UC 309
50	90	51,6	22	62,1	32,6	1,1	35,1	23,2	1,0	3 300	0,74	UC 210
	110	61	30	69,1	39	3	61,8	38,0	1,6	3 400	1,65	UC 310
55	100	55,6	25	70,0	33,4	1,5	43,6	29,0	1,3	3 000	1,07	UC 211
	120	66	32	76,1	41	3	71,5	45,0	1,9	3 100	2,10	UC 311
60	110	65,1	27	77,0	39,7	1,5	52,7	36,0	1,5	2 700	1,50	UC 212
	130	71	35	81,7	45	3,5	81,9	52,0	2,2	2 900	2,6	UC 312
65	120	65,1	27	82,1	39,7	1,5	57,2	40,0	1,7	2 350	1,81	UC 213
70	125	74,6	29	87,0	44,4	1,5	62,4	44,0	1,9	2 250	2,01	UC 214
75	130	77,8	30	91,5	44,5	1,5	66,3	49,0	2,0	2 100	2,20	UC 215
	160	82	43	101,3	50	3,5	114,0	76,5	3,0	2 300	4,65	UC 315
80	140	82,6	32	98,5	49,3	2,0	71,5	54,0	2,2	1 900	2,79	UC 216
	170	86	44	107,9	52	3,5	124,0	86,5	3,25	2 150	5,45	UC 316
85	150	85,7	34	105,0	51,6	2,0	83,2	64,0	2,5	1 800	3,38	UC 217
90	160	96,0	36	111,5	56,3	2,0	95,6	72,0	2,7	1 600	4,23	UC 218
100	215	108	54	135,5	66	4,5	174,0	140,0	4,75	1 700	10,9	UC 320

Insert bearings with set screws, inch shafts

d 3/4 – 4 in

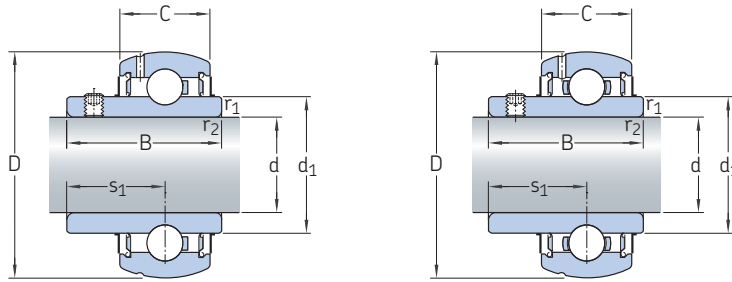

Polymer cage for size 204-12 to 209-28

Pressed steel cage for size 211-32 and above

Dimensions							Basic load ratings		Fatigue load limit	Limiting speed with shaft tolerance h6	Mass	Designation
d	D	B	C	d ₁	s ₁	r _{1,2} min.	C	C ₀	P _u	r/min	kg	–
in/mm							kN		kN	r/min	kg	–
3/4 19,05	47	31,0	15	28,7	18,3	1	12,7	6,7	0,3	6 500	0,16	UC 204-12
7/8 22,225	52	34,0	15	33,7	19,7	1	14,0	7,8	0,3	5 850	0,21	UC 205-14
15/16 23,813	52	34,0	15	33,7	19,7	1	14,0	7,8	0,3	5 850	0,20	UC 205-15
1 25,4	52	34,0	15	33,7	19,7	1	14,0	7,8	0,3	5 850	0,18	UC 205-16
1 1/8 28,575	62	38,1	18	39,8	22,2	1	19,5	11,4	0,5	5 000	0,32	UC 206-18
1 3/16 30,163	62	38,1	18	39,8	22,2	1	19,5	11,4	0,5	5 000	0,30	UC 206-19
1 1/4 31,75	72	42,9	19	46,8	25,4	1,1	25,5	15,3	0,7	4 300	0,52	UC 207-20
1 3/8 34,925	72	42,9	19	46,8	25,4	1,1	25,5	15,3	0,7	4 300	0,47	UC 207-22
1 7/16 36,513	72	42,9	19	46,8	25,4	1,1	25,5	15,3	0,7	4 300	0,43	UC 207-23
1 1/2 38,1	80	49,2	22	52,5	30,2	1,1	32,5	20,0	0,9	3 750	0,65	UC 208-24
1 3/4 44,45	85	49,2	22	57,3	30,2	1,1	32,5	20,4	0,9	3 400	0,69	UC 209-28
2 50,8	100	55,6	25	70	33,4	1,5	43,6	29,0	1,3	3 000	1,22	UC 211-32
2 1/4 57,15	110	65,1	27	77	39,7	1,5	52,7	36,0	1,5	2 700	1,37	UC 212-36
2 1/2 63,5	120	65,1	27	82,1	39,7	1,5	57,0	40,0	1,7	2 350	1,73	UC 213-40
3 76,2	160	82	43	101,3	50	3,5	114	76,5	3	2 300	4,55	UC 315-48
4 101,6	215	108	54	135,5	66	4,5	174	140	4,75	1 700	10,7	UC 320-64

Insert bearing pillow block units, set screws, for metric shafts

d 20 – 100 mm

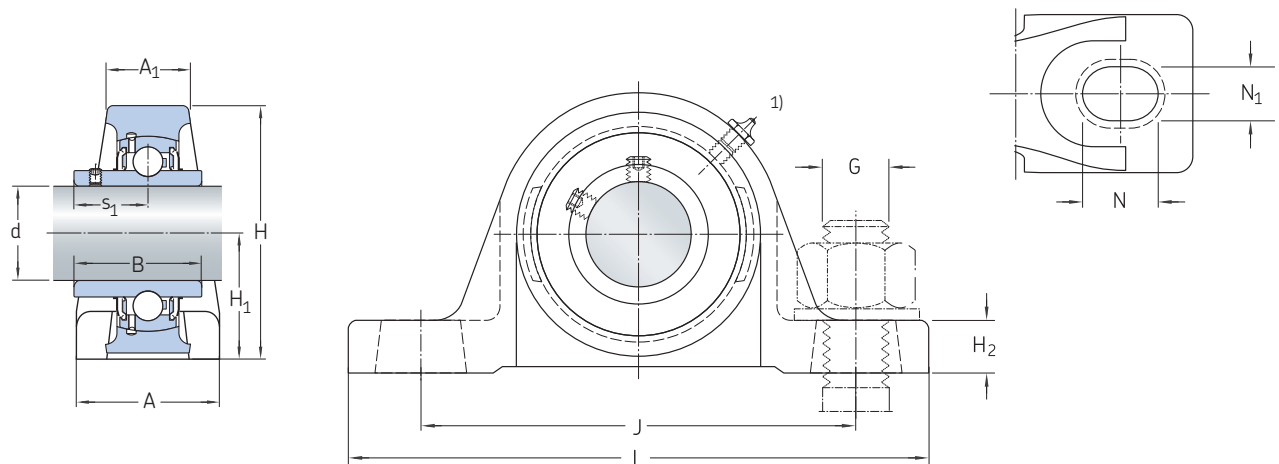

Dimension	Basic load ratings		Fatigue load limit	Limiting speed with shaft tolerance	Mass	Designations		Unit
	dynamic	static				Housing	Bearing	
d	C	C ₀	P _u	h6				
mm	kN		kN	r/min	kg	–		
20	12,7	6,7	0,3	6 500	0,66	P 204	UC 204	UCP 204
25	14,0	7,8	0,3	5 850	0,86	P 205	UC 205	UCP 205
30	19,5 26,5	11,4 15	0,5 0,64	5 000 5 300	1,34 2,15	P 206 P 306	UC 206 UC 306	UCP 206 UCP 306
35	25,5 33,2	15,3 19,3	0,7 0,815	4 300 4 700	1,62 3,00	P 207 P 307	UC 207 UC 307	UCP 207 UCP 307
40	32,5 41,0	20,0 24,0	0,9 1,02	3 750 4 200	2,17 3,55	P 208 P 308	UC 208 UC 308	UCP 208 UCP 308
45	32,5 52,7	20,4 32,0	0,9 1,34	3 400 3 750	2,40 5,05	P 209 P 309	UC 209 UC 309	UCP 209 UCP 309
50	35,1 61,8	23,2 38,0	1,0 1,6	3 300 3 400	2,88 6,40	P 210 P 310	UC 210 UC 310	UCP 210 UCP 310
55	43,6 71,5	29,0 45,0	1,3 1,9	3 000 3 100	3,95 7,80	P 211 P 311	UC 211 UC 311	UCP 211 UCP 311
60	52,7 81,9	36,0 52,0	1,5 2,2	2 700 2 900	5,05 9,6	P 212 P 3112	UC 212 UC 312	UCP 212 UCP 312
65	57,2	40,0	1,7	2 350	6,63	P 213	UC 213	UCP 213
70	62,4	44,0	1,9	2 250	7,17	P 214	UC 214	UCP 214
75	66,3 114,0	49,0 76,5	2,0 3,0	2 100 2 300	8,17 15,5	P 215 P 315	UC 215 UC 315	UCP 215 UCP 315
80	71,5 124,0	54,0 86,5	2,2 3,25	1 900 2 150	9,30 18,2	P 216 P 316	UC 216 UC 316	UCP 216 UCP 316
85	83,2	64,0	2,5	1 800	12,9	P 217	UC 217	UCP 217
90	95,6	72,0	2,7	1 600	14,5	P 218	UC 218	UCP 218
100	174,0	140,0	4,75	1 700	36,7	P 320	UC 320	UCP 320

¹⁾ The grease nipple is centered on the housing for size 210 and above.

Dimensions

d	A	A ₁	B	H	H ₁	H ₂	J	L	N	N ₁	G	s ₁
mm										–	mm	
20	34	20,8	31	64,29	33,3	13,49	95	127	18	13	M10	18,3
25	38,1	21,27	34	70,64	36,5	15,88	105	139,7	18	13	M10	19,7
30	44,6 47	23,6 31,6	38,1 43	83,34 100	42,9 50	16,67 21	121 140	165,1 182	21 19	17 17	M14 M14	22,2 26
35	45,8 54	26,7 35,8	42,9 48	93,66 111,4	47,6 56	18,26 23	127 160,5	166,69 209	21 24,5	17 17	M14 M14	25,4 29
40	48,8 57	29 37,8	49,2 52	101 119,4	49,2 60	20,64 25	137 170,5	184,15 221	21 26,5	17 17	M14 M14	30,2 33
45	51,2 63	29,3 41,8	49,2 57	107,95 136	54 67	19,05 25	146 190	189,71 247	21 29	17 20	M14 M16	30,2 35
50	55,6 65	30,7 43	51,6 61	115,89 152	57,2 75	19,05 25	159 212,5	206,38 275	22 34,5	20 20	M16 M16	32,6 39
55	58,9 68	34,6 45	55,6 66	126,21 162	63,5 80	22,23 25	171 236,5	219,08 302	22 37,5	20 20	M16 M16	33,4 41
60	61,6 72	34,3 47,8	65,1 71	141,29 170,8	69,8 85	22,23 35	184 250,5	239,71 321	25 36,5	20 24	M16 M20	39,7 45
65	71,9	34,9	65,1	153,59	76,2	25,4	203	265,11	30	25	M20	39,7
70	72,1	40,5	74,6	159,54	79,4	28,18	210	265,91	30	25	M20	44,4
75	73 86	42 57,6	77,8 82	166 202	82,6 100	25,4 40	217 290,5	271,47 368	30 39,5	25 27	M20 M22	44,5 50
80	77,8 93	45,2 61,8	82,6 86	176,21 215	88,9 106	34 40	232 300,5	292,1 378	35 39,5	25 27	M20 M22	49,3 52
85	83,2	47,6	85,7	188,91	95,2	36	247	310,36	35	25	M20	51,6
90	88	50,8	96	202,41	101,6	38	262	327,03	40	27	M22	56,3
100	107	71,4	108	283	140	55	380	482	49,5	36	M30	66

Insert bearing pillow block units, set screws, for inch shaft

d 3/4 – 4 in

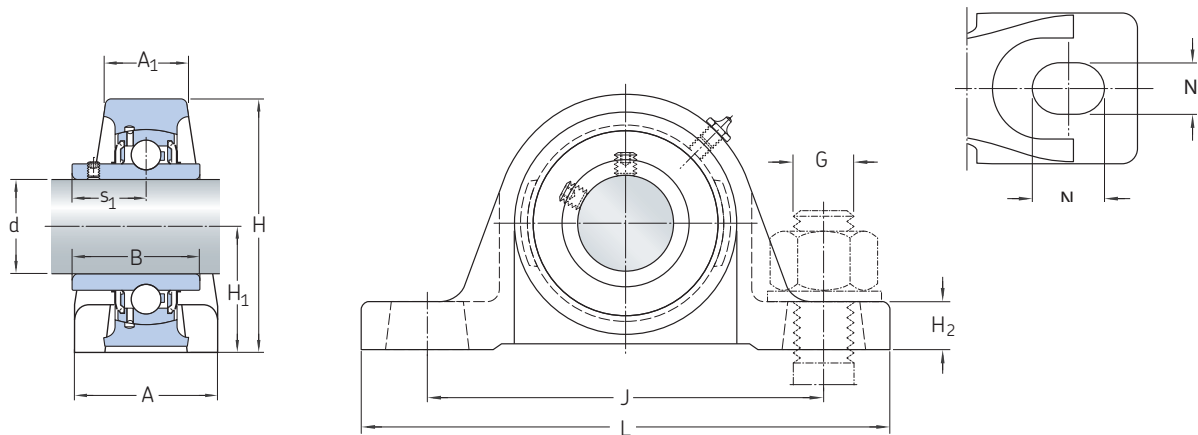

Principal dimensions	Basic load ratings		Fatigue load limit	Limiting speed with shaft tolerance h6	Mass	Designations Housing	Bearing	Unit
	dynamic	static						
d	C	C ₀	P _u					
in/mm	kN			r/min	kg	–		
3/4 19,05	12,7	6,7	0,3	6 500	0,67	P 204	UC 204-12	UCP 204-12
7/8 22,225	14,0	7,8	0,3	5 850	0,89	P 205	UC 205-14	UCP 205-14
15/16 23,813	14,0	7,8	0,3	5 850	0,88	P 205	UC 205-15	UCP 205-15
1 25,4	14,0	7,8	0,3	5 850	0,86	P 205	UC 205-16	UCP 205-16
1 1/8 28,575	19,5	11,4	0,5	5 000	1,36	P 206	UC 206-18	UCP 206-18
1 3/16 30,163	19,5	11,4	0,5	5 000	1,34	P 206	UC 206-19	UCP 206-19
1 1/4 31,75	25,5	15,3	0,7	4 300	1,67	P 207	UC 207-20	UCP 207-20
1 3/8 34,925	25,5	15,3	0,7	4 300	1,62	P 207	UC 207-22	UCP 207-22
1 7/16 36,513	25,5	15,3	0,7	4 300	1,59	P 207	UC 207-23	UCP 207-23
1 1/2 38,1	32,5	20,0	0,9	3 750	2,22	P 208	UC 208-24	UCP 208-24
1 3/4 44,45	32,5	20,4	0,9	3 400	2,41	P 209	UC 209-28	UCP 209-28
2 50,8	43,6	29,0	1,3	3 000	4,10	P 211	UC 211-32	UCP 211-32
2 1/4 57,15	52,7	36,0	1,5	2 700	5,18	P 212	UC 212-36	UCP 212-36
2 1/2 63,5	57,2	40,0	1,7	2 350	6,70	P 213	UC 213-40	UCP 213-40
3 76,2	114	76,5	3	2 300	15,4	P315	UCP 315-48	UCP 315-48
4 101,6	174	140	4,75	1 700	36,4	P320	UCP 320-64	UCP 320-64

Dimensions

d	A	A ₁	B	H	H ₁	H ₂	J	L	N	N ₁	G	s ₁
in/mm	mm										–	mm
3/4 19,05	34	20,8	31	64,29	33,3	13,49	95	127	18	13	M10	18,3
7/8 22,225	38,1	21,27	34	70,64	36,5	15,88	105	139,7	18	13	M10	19,7
15/16 23,813	38,1	21,27	34	70,64	36,5	15,88	105	139,7	18	13	M10	19,7
1 25,4	38,1	21,27	34	70,64	36,5	15,88	105	139,7	18	13	M10	19,7
1 1/8 28,575	44,6	23,6	38,1	83,34	42,9	16,67	121	165,1	21	17	M10	22,2
1 3/16 30,163	44,6	23,6	38,1	83,34	42,9	16,67	121	165,1	21	17	M10	22,2
1 1/4 31,75	45,8	26,7	42,9	93,66	47,6	18,26	127	166,69	21	17	M12	25,4
1 3/8 34,925	45,8	26,7	42,9	93,66	47,6	18,26	127	166,69	21	17	M12	25,4
1 7/16 36,513	45,8	26,7	42,9	93,66	47,6	18,26	127	166,69	21	17	M12	25,4
1 1/2 38,1	48,8	29	49,2	101	49,2	20,64	137	184,15	21	17	M14	30,2
1 3/4 44,45	51,2	29,3	49,2	107,95	54	19,05	146	189,71	21	17	M14	30,2
2 50,8	58,9	34,6	55,6	126,21	63,5	22,23	171	219,08	22	20	M16	33,4
2 1/4 57,15	61,6	34,3	65,1	141,29	69,8	22,23	184	239,71	25	20	M16	39,7
2 1/2 63,5	71,9	34,9	65,1	153,59	76,2	25,4	203	265,11	30	25	M16	39,7
3 76,2	86	57,6	82	202,7	100	40	290	368	39,5	27	22	50
4 101,6	107	71,4	108	283,7	140	55	380	482	49,5	36	30	66

Insert bearing flanged units with square 4-bolt flange housing, set screws, for metric shafts

d 20 – 100 mm

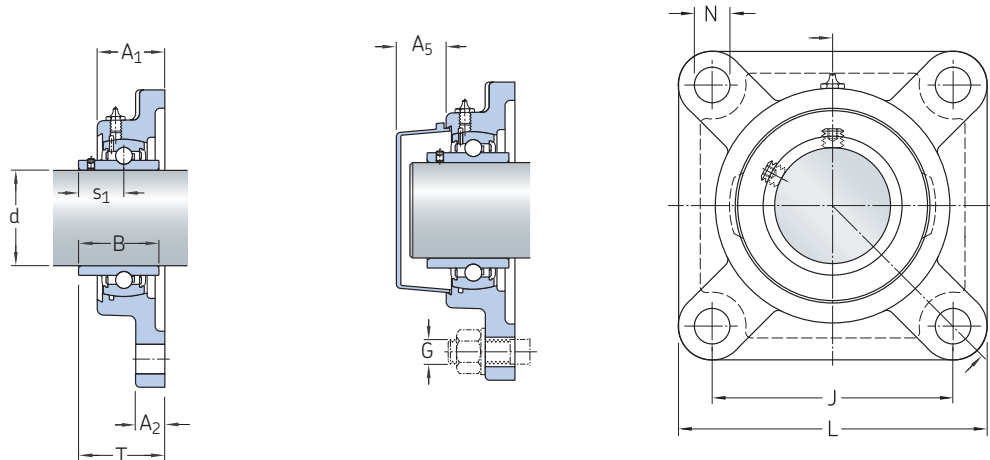

Dimension	Basic load ratings		Fatigue load limit	Limiting speed with shaft tolerance h6	Mass	Designations			Unit
	dynamic	static				Housing	Bearing	Appropriate end cover	
d	C	C ₀	P _u						
mm	kN		kN	r/min	kg	–			
20	12,7	6,7	0,3	6 500	0,49	F 204	UC 204	ECY 204	UCF 204
25	14,0	7,8	0,3	5 850	0,63	F 205	UC 205	ECY 205	UCF 205
30	19,5 26,5	11,4 15,0	0,5 0,64	5 000 5 300	0,89 1,75	F 206 F 306	UC 206 UC 306	ECY 206 –	UCF 206 UCF 306
35	25,5 33,2	15,3 19,3	0,7 0,815	4 300 4 700	1,25 2,1	F 207 F 307	UC 207 UC 307	ECY 207 –	UCF 207 UCF 307
40	32,5 41,0	20,0 24,0	0,9 1,02	3 750 4 200	1,69 2,95	F 208 F 308	UC 208 UC 308	ECY 208 –	UCF 208 UCF 308
45	32,5 52,7	20,4 32,0	0,9 1,34	3 400 3 750	1,96 3,80	F 209 F 309	UC 209 UC 309	ECY 209 –	UCF 209 UCF 309
50	35,1 61,8	23,2 38,0	1,0 1,6	3 300 3 400	2,23 5,05	F 210 F 310	UC 210 UC 310	ECY 210 –	UCF 210 UCF 310
55	43,6 71,5	29,0 45,0	1,3 1,9	3 000 3 100	3,60 5,5	F 211 F 311	UC 211 UC 311	ECY 211 –	UCF 211 UCF 311
60	52,7 81,9	36,0 52,0	1,5 2,2	2 700 2 900	3,97 7	F 212 F 312	UC 212 UC 312	ECY 212 –	UCF 212 UCF 312
65	57,2	40,0	1,7	2 350	5,08	F 213	UC 213	ECY 213	UCF 213
70	62,4	44,0	1,9	2 250	5,34	F 214	UC 214	ECY 214	UCF 214
75	66,3 114,0	49,0 76,5	2,0 3,0	2 100 2 300	5,86 11,6	F 215 F 315	UC 215 UC 315	ECY 215 –	UCF 215 UCF 315
80	71,5 124,0	54,0 86,5	2,2 3,25	1 900 2 150	7,02 15,4	F 216 F 316	UC 216 UC 316	ECY 216 –	UCF 216 UCF 316
85	83,2	64,0	2,5	1 800	8,91	F 217	UC 217	ECY 217	UCF 217
90	95,6	72,0	2,7	1 600	11,38	F 218	UC 218	ECY 218	UCF 218
100	174,0	140,0	4,75	1 700	29,8	F 320	UC 320	–	UCF 320

Dimensions

d	A ₁	A ₂	B	J	L	N	G	s ₁	T	A ₅
mm							–	mm		
20	25,4	11,1	31	64	85,7	12	M10	18,3	33,3	18,5
25	26,9	12,7	34	70	95,3	12	M10	19,7	35,7	18
30	30 33,8	14,3 16	38,1 43	83 95	108 127	12 16	M10 M14	22,2 26	40,2 44	20 –
35	32 38	15,1 17	42,9 48	92 100	117,5 137	14 19	M12 M16	25,4 29	44,4 49	22 –
40	35,7 42	15,1 18	49,2 52	102 112	130,2 149	16 19	M14 M16	30,2 33	51,2 56	23,5 –
45	38,1 45,8	15,9 19	49,2 57	105 125	136,5 162	16 19	M14 M16	30,2 35	52,2 60	23 –
50	39,7 49,5	15,9 20	51,6 61	111 132	142,9 175	16 23	M14 M20	32,6 39	54,6 67	29,5 –
55	42,9 52,9	18,3 21	55,6 66	130 140	161,9 183	19 23	M16 M20	33,4 41	58,4 71	34 –
60	47,6 57,4	18,3 23	65,1 71	143 150	174,6 193	19 23	M16 M20	39,7 45	68,7 78	35,5 –
65	50	22,2	65,1	149	187,3	19	M16	39,7	69,7	35,5
70	53,9	22,2	74,6	152	192,9	19	M16	44,4	75,4	38,5
75	56,4 68	22,2 26	77,8 82	159 184	200 229	19 25	M16 M22	44,5 50	78,5 89	38,5 –
80	57,9 68,7	22,2 28	82,6 86	165 196	207,9 252	23 31	M20 M28	49,3 52	83,3 90	41,5 –
85	62,7	23,8	85,7	175	219,9	23	M20	51,6	87,6	43,2
90	68,3	25,4	96	187	234,9	23	M20	56,3	96,3	45,3
100	94,5	33	108	242	312	38	M33	66	125	–

Insert bearing flanged units with 4-bolt flange housing, set screws, for inch shaft

d 3/4 – 4 in

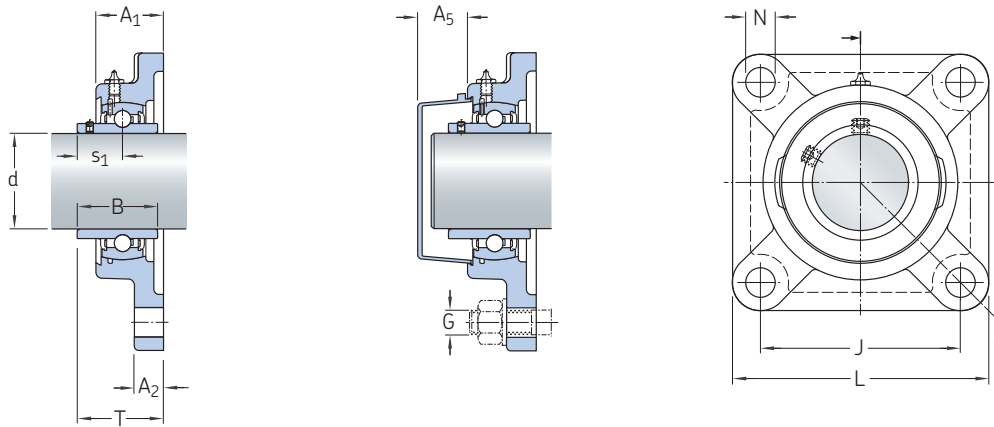

Principal dimensions	Basic load ratings		Fatigue load limit	Limiting speed with shaft tolerance h6	Mass	Designations		Appropriate end cover	Unit
	dynamic	static				Housing	Bearing		
d	C	C ₀	P _u						
in/mm	kN			r/min	kg	–			
3/4 19,05	12,7	6,7	0,3	6 500	0,50	F 204	UC 204-12	ECY204	UCF 204-12
7/8 22,225	14,0	7,8	0,3	5 850	0,65	F 205	UC 205-14	ECY205	UCF 205-14
15/16 23,813	14,0	7,8	0,3	5 850	0,64	F 205	UC 205-15	ECY205	UCF 205-15
1 25,4	14,0	7,8	0,3	5 850	0,62	F 205	UC 205-16	ECY205	UCF 205-16
1 1/8 28,575	19,5	11,4	0,5	5 000	0,91	F 206	UC 206-18	ECY206	UCF 206-18
1 3/16 30,163	19,5	11,4	0,5	5 000	0,89	F 206	UC 206-19	ECY206	UCF 206-19
1 1/4 31,75	25,5	15,3	0,7	4 300	1,31	F 207	UC 207-20	ECY 207	UCF 207-20
1 3/8 34,925	25,5	15,3	0,7	4 300	1,25	F 207	UC 207-22	ECY 207	UCF 207-22
1 7/16 36,513	25,5	15,3	0,7	4 300	1,22	F 207	UC 207-23	ECY 207	UCF 207-23
1 1/2 38,1	32,5	20,0	0,9	3 750	1,73	F 208	UC 208-24	ECY208	UCF 208-24
1 3/4 44,45	32,5	20,4	0,9	3 400	1,97	F 209	UC 209-28	ECY209	UCF 209-28
2 50,8	43,6	29,0	1,3	3 000	3,75	F 211	UC 211-32	ECY211	UCF 211-32
2 1/4 57,15	52,7	36,0	1,5	2 700	4,10	F 212	UC 212-36	ECY212	UCF 212-36
2 1/2 63,5	57,2	40,0	1,7	2 350	5,16	F 213	UC 213-40	ECY213	UCF 213-40
3 76,2	114	76,5	3	2 300	11,6	F315	UCF 315-48	ECP 315	UCF 315-48
4 101,6	174	140	4,75	1 700	29,5	F320	UCF 320-64	ECP 320	UCF 320-64

Dimensions

d	A ₁	A ₂	B	J	L	N	G	s ₁	T	A ₅
in/mm	mm						–	mm		
3/4 19,05	25,4	11,1	31	64	85,7	12	M10	18,3	33,3	18,5
7/8 22,225	26,9	12,7	34	70	95,3	12	M10	19,7	35,7	18
15/16 23,813	26,9	12,7	34	70	95,3	12	M10	19,7	35,7	18
1 25,4	26,9	12,7	34	70	95,3	12	M10	19,7	35,7	18
1 1/8 28,575	30	14,3	38,1	83	108	12	M10	22,2	40,2	20
1 3/16 30,163	30	14,3	38,1	83	108	12	M10	22,2	40,2	20
1 1/4 31,75	32	15,1	42,9	92	117,5	14	M12	25,4	44,4	22
1 3/8 34,925	32	15,1	42,9	92	117,5	14	M12	25,4	44,4	22
1 7/16 36,513	32	15,1	42,9	92	117,5	14	M12	25,4	44,4	22
1 1/2 38,1	35,7	15,1	49,2	102	130,2	16	M14	30,2	51,2	23,5
1 3/4 44,45	38,1	15,9	49,2	105	136,5	16	M14	30,2	52,2	23
2 50,8	42,9	18,3	55,6	130	161,9	19	M16	33,4	58,4	34
2 1/4 57,15	47,6	18,3	65,1	143	174,6	19	M16	39,7	68,7	35,5
2 1/2 63,5	50	22,2	65,1	149	187,3	19	M16	39,7	69,7	35,5
3 76,2	68	26	82	184	229	25	22	50	89	–
4 101,6	94,5	33	108	242	312	38	33	66	125	–

Insert bearing flanged unit with round 4-bolt flange housing, set screws, for metric shafts

d 20 – 90 mm

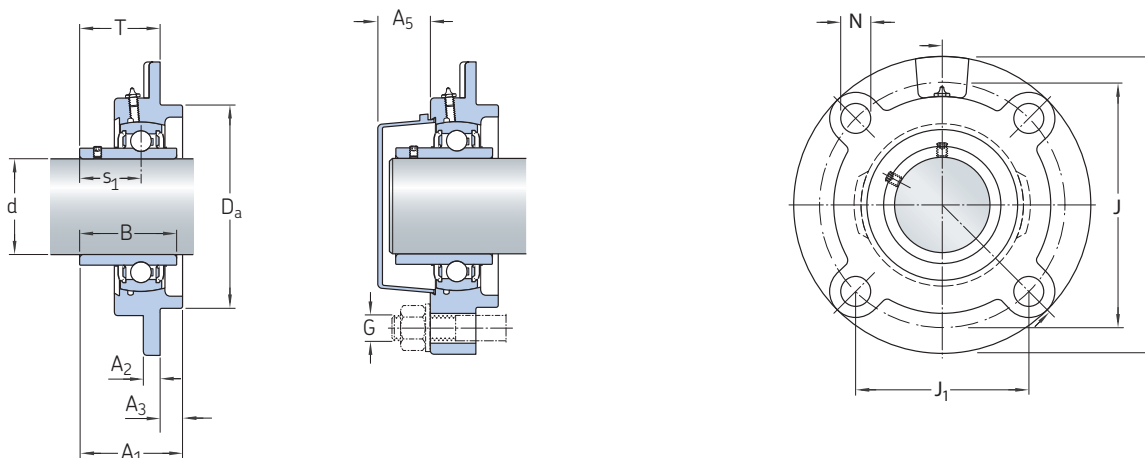

Dimension	Basic load ratings		Fatigue load limit	Limiting speed with shaft tolerance h6	Mass	Designations			Unit
	dynamic	static				Housing	Bearing	Appropriate end cover	
d	C	C ₀	P _u						
mm	kN		kN	r/min	kg	–			
20	12,7	6,7	0,3	6 500	0,72	FC 204	UC 204	ECY 204	UCFC 204
25	14,0	7,8	0,3	5 850	1,01	FC 205	UC 205	ECY 205	UCFC 205
30	19,5	11,4	0,5	5 000	1,29	FC 206	UC 206	ECY 206	UCFC 206
35	25,5	15,3	0,7	4 300	1,61	FC 207	UC 207	ECY 207	UCFC 207
40	32,5	20,0	0,9	3 750	2,02	FC 208	UC 208	ECY 208	UCFC 208
45	32,5	20,4	0,9	3 400	2,45	FC 209	UC 209	ECY 209	UCFC 209
50	35,1	23,2	1,0	3 300	2,95	FC 210	UC 210	ECY 210	UCFC 210
55	43,6	29,0	1,3	3 000	4,26	FC 211	UC 211	ECY 211	UCFC 211
60	52,7	36,0	1,5	2 700	5,10	FC 212	UC 212	ECY 212	UCFC 212
65	57,2	40,0	1,7	2 350	5,70	FC 213	UC 213	ECY 213	UCFC 213
70	62,4	44,0	1,9	2 250	6,87	FC 214	UC 214	ECY 214	UCFC 214
75	66,3	49,0	2,0	2 100	7,86	FC 215	UC 215	ECY 215	UCFC 215
80	71,5	54,0	2,2	1 900	9,12	FC 216	UC 216	ECY 216	UCFC 216
85	83,2	64,0	2,5	1 800	10,3	FC 217	UC 217	ECY 217	UCFC 217
90	95,6	72,0	2,7	1 600	11,9	FC 218	UC 218	ECY 218	UCFC 218

Dimensions

d	A ₁	A ₂	A ₃	B	D _a	J	J ₁	L	N	G	s ₁	T	A ₅
mm										–	mm		
20	26	10	5	31	62	78	55,1	100	12	M10	18,3	28,3	18,5
25	27,3	10	6	34	70	90	63,6	115,1	12	M10	19,7	29,7	18
30	30	10	8	38,1	80	100	70,7	124,6	12	M10	22,2	32,2	20
35	32	11	8	42,9	90	110	77,8	134,9	14	M12	25,4	36,4	22
40	35,7	11	10	49,2	100	120	84,8	145,3	14	M12	30,2	41,2	23,5
45	37,6	10	12	49,2	105	132	93,3	160,3	16	M14	30,2	40,2	23
50	38,8	10	12	51,6	110	138	97,6	165,1	16	M14	32,6	42,6	29,5
55	43	13	12	55,6	125	150	106,1	184,9	19	M16	33,4	46,4	34
60	47,6	17	12	65,1	135	160	113,1	195,3	19	M16	39,7	56,7	35,5
65	50	16	14	65,1	145	170	120,2	204,8	19	M16	39,7	55,7	35,5
70	53,9	17	14	74,6	150	177	125,1	215,1	19	M16	44,4	61,4	38,5
75	55,9	18	16	77,8	160	184	130,1	220	19	M16	44,5	62,5	38,5
80	57,9	18	16	82,6	170	200	141,4	239,7	23	M20	49,3	67,3	41,5
85	62,7	18	18	85,7	180	208	147,1	250	23	M20	51,6	69,6	43,2
90	68,3	22	18	96	190	220	155,5	265,1	23	M20	56,3	78,3	45,3

Insert bearing flanged units with oval 2-bolt flange housing, set screws, for metric shafts

d 20 – 90 mm

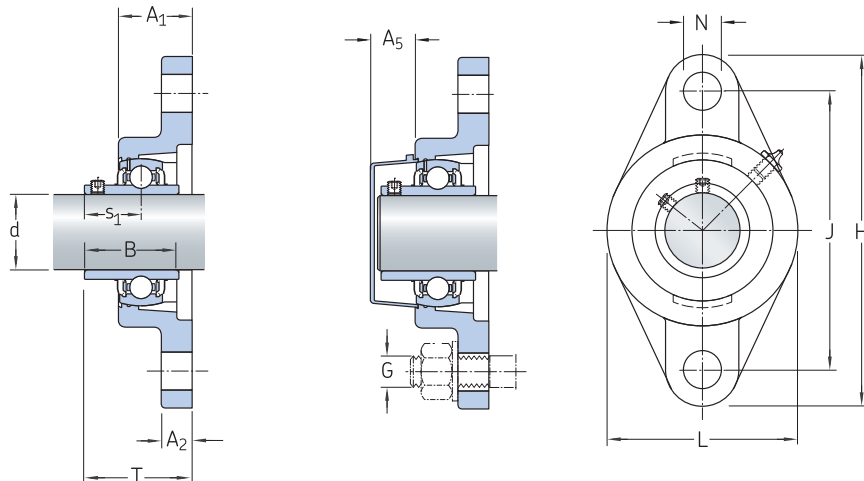

Dimension	Basic load ratings		Fatigue load limit	Limiting speed with shaft tolerance	Mass	Designations		Appropriate end cover	Unit
	dynamic	static				Housing	Bearing		
d	C	C ₀	P _u	h6					
mm	kN		kN	r/min	kg	–			
20	12,7	6,7	0,3	6 500	0,44	FL 204	UC 204	ECY 204	UCFL 204
25	14,0	7,8	0,3	5 850	0,62	FL 205	UC 205	ECY 205	UCFL 205
30	19,5	11,4	0,5	5 000	0,90	FL 206	UC 206	ECY 206	UCFL 206
35	25,5	15,3	0,7	4 300	1,19	FL 207	UC 207	ECY 207	UCFL 207
40	32,5	20,0	0,9	3 750	1,53	FL 208	UC 208	ECY 208	UCFL 208
45	32,5	20,4	0,9	3 400	1,84	FL 209	UC 209	ECY 209	UCFL 209
50	35,1	23,2	1,0	3 300	2,17	FL 210	UC 210	ECY 210	UCFL 210
55	43,6	29,0	1,3	3 000	3,12	FL 211	UC 211	ECY 211	UCFL 211
60	52,7	36,0	1,5	2 700	3,99	FL 212	UC 212	ECY 212	UCFL 212
65	57,2	40,0	1,7	2 350	4,93	FL 213	UC 213	ECY 213	UCFL 213
70	62,4	44,0	1,9	2 250	5,46	FL 214	UC 214	ECY 214	UCFL 214
75	66,3	49,0	2,0	2 100	5,99	FL 215	UC 215	ECY 215	UCFL 215
80	71,5	54,0	2,2	1 900	7,52	FL 216	UC 216	ECY 216	UCFL 216
85	83,2	64,0	2,5	1 800	8,83	FL 217	UC 217	ECY 217	UCFL 217
90	95,6	72,0	2,7	1 600	10,70	FL 218	UC 218	ECY 218	UCFL 218

Dimensions

d	A ₁	A ₂	B	H	J	L	N	G	s ₁	T	A ₅
mm								–	mm		
20	25,5	11,1	31	113	90	60,3	12	M10	18,3	33,3	18,5
25	27	12,7	34	130,2	99	68,3	16	M14	19,7	35,7	18
30	30	12,7	38,1	147,6	117	80,2	16	M14	22,2	40,2	20
35	32	14,3	42,9	161,1	130	89,7	16	M14	25,4	44,4	22
40	34	14,3	49,2	174,6	144	100	16	M14	30,2	51,2	23,5
45	35	15,1	49,2	188,1	148	108	19	M16	30,2	52,2	23
50	39	15,1	51,6	196,9	157	115,1	19	M16	32,6	54,6	29,5
55	41,4	18,3	55,6	223,8	184	130,2	19	M16	33,4	58,4	34
60	45	18,3	65,1	250	202	139,7	23	M20	39,7	68,7	35,5
65	47	19,8	65,1	258	210	154,8	23	M20	39,7	69,7	35,5
70	50	19,8	74,6	265,1	216	160,3	23	M20	44,4	75,4	38,5
75	54	20	77,8	275	225	164	23	M20	44,5	78,5	38,5
80	56	20	82,6	290	233	180	25	M22	49,3	83,3	41,5
85	60	22	85,7	305	248	190	25	M22	51,6	87,6	43,2
90	68	23	96	320	265	205	25	M22	56,3	96,3	45,3

3-bolt bracket flanged ball bearing units, set screws, for metric shafts
d 20 – 45 mm

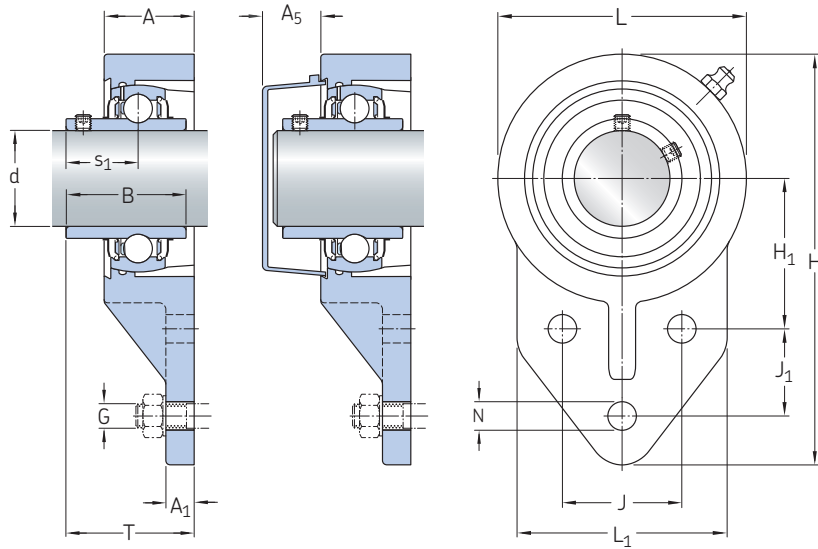

Principal dimensions	Basic load ratings		Fatigue load limit	Limiting speed with shaft tolerance h6	Mass	Designations			
	dynamic	static				Housing	Bearings	Appropriate end cover	Units
d	C	C ₀	P _u						
mm	kN			r/min	kg	–			
20	12,7	6,7	0,285	6 500	0,59	FB 204	UC 204	ECY204	UCFB 204
25	14	7,8	0,335	5 850	0,72	FB 205	UC 205	ECY205	UCFB 205
30	19,5	11,4	0,5	5 000	0,98	FB 206	UC 206	ECY 206	UCFB 206
35	25,5	15,3	0,7	4 300	1,29	FB 207	UC 207	ECY 207	UCFB 207
40	32,5	20,0	0,9	3 750	1,70	FB 208	UC 208	ECY 208	UCFB 208
45	32,5	20,4	0,9	3 400	1,99	FB 209	UC 209	ECY 209	UCFB 209

Dimensions

d	H	L	A	J	J ₁	N	H ₁	L ₁	A ₁	A ₅	T	B	S ₁	G
mm														
20	111,9	63,5	25,4	32	27	9,5	42	63,5	8	20,5	31,8	31	18,3	M8
25	118,1	69,9	27,2	34	27	9,5	45	66	9,5	20,5	34,7	34	19,7	M8
30	136,5	82,6	30	40	29	9,5	50	69,9	9,5	22,5	40,9	38,1	15,9	M8
35	144	90	33,5	46	32	9,5	55	82,6	12,7	24,5	44,4	42,9	17,5	M8
40	164,3	100	35,7	50	41	11	60	77,8	15,9	26	51,2	49,2	19	M10
45	175,5	106,4	36,8	54	43	11	65	80,2	18,3	26,5	50,2	49,2	19	M10

Take-up ball bearing units, set crews, for metric shafts
d 20 – 85 mm

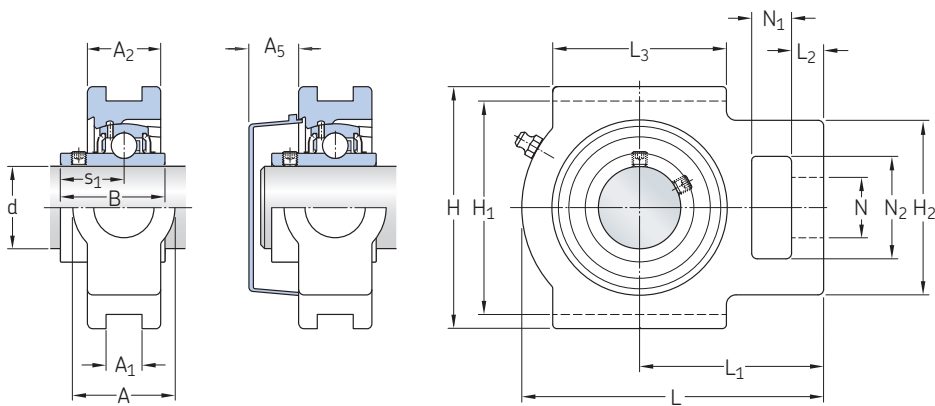

Principal dimensions	Basic load ratings		Fatigue load limit	Limiting speed with shaft tolerance h6	Mass	Designations	Bearings	Appropriate end cover	Units
	dynamic	static							
d	C	C ₀	P _u			Housing			
mm	kN			r/min	kg	–			
20	12,7	6,7	0,3	6 500	0,70	T 204	UC 204	ECY 204	UCT 204
25	14,0	7,8	0,3	5 850	0,78	T 205	UC 205	ECY 205	UCT 205
30	19,5	11,4	0,5	5 000	1,22	T 206	UC 206	ECY 206	UCT 206
35	25,5	15,3	0,7	4 300	1,62	T 207	UC 207	ECY 207	UCT 207
40	32,5	20,0	0,9	3 750	2,37	T 208	UC 208	ECY 208	UCT 208
45	32,5	20,4	0,9	3 400	2,33	T 209	UC 209	ECY 209	UCT 209
50	35,1	23,2	1,0	3 300	2,50	T 210	UC 210	ECY 210	UCT 210
55	43,6	29,0	1,3	3 000	3,92	T 211	UC 211	ECY 211	UCT 211
60	52,7	36,0	1,5	2 700	4,81	T 212	UC 212	ECY 212	UCT 212
65	57,2	40,0	1,7	2 350	6,78	T 213	UC 213	ECY 213	UCT 213
70	62,4	44,0	1,9	2 250	6,93	T 214	UC 214	ECY 214	UCT 214
75	66,3	49,0	2,0	2 100	7,75	T 215	UC 215	ECY 215	UCT 215
80	71,5	54,0	2,2	1 900	8,18	T 216	UC 216	ECY 216	UCT 216
85	83,2	64,0	2,5	1 800	10,88	T 217	UC 217	ECY 217	UCT 217

Dimensions

d	A	A ₁	A ₂	A ₅	H	H ₁	H ₂	L	L ₁	L ₂	L ₃	N	N ₁	N ₂	B	S ₁
mm																
20	31,8	12	20,6	20,5	88,9	76	50,8	96	61,1	10,3	50,8	19	15,9	31,8	31	18,3
25	31,8	12	23,8	20,5	88,9	76	50,8	99	61,9	10,3	50,8	19	15,9	31,8	34	19,7
30	37,3	12	27,8	22,5	102,4	89	56,4	115	69,9	10,3	57,2	22	15,9	37,3	38,1	22,2
35	37,3	12	30,2	24,5	102,4	89	64,3	131	77,8	12,7	64,3	22	15,9	37,3	42,9	25,4
40	49,2	16	33,3	26	114,3	102	83,3	146	88,1	15,9	83,3	29	19,1	49,2	49,2	30,2
45	49,2	16	34,9	26,5	116,7	102	83,3	146	87,3	15,9	83,3	29	21,1	51,2	49,2	30,2
50	49,2	16	37,3	33	116,7	102	83,3	151	89,7	15,9	85,7	29	19,1	49,2	51,6	32,6
55	64,3	22	38,1	37,5	146,1	130	102,4	173	106,4	19,1	95,3	35	25,4	64,3	55,6	33,4
60	64,3	22	42,1	39	146,1	130	102,4	196	119,1	19,1	102,4	35	31,8	64,3	65,1	39,4
65	69,9	26	43,7	39	166,7	151	111,1	226	137,3	20,6	120,7	41	31,8	69,9	65,1	39,4
70	69,9	26	46	41,5	166,7	151	111,1	226	137,3	20,6	120,7	41	31,8	69,9	74,6	44,4
75	69,9	26	47,6	41,5	166,7	151	111,1	234	139,7	20,6	120,7	41	31,8	69,9	77,8	44,5
80	69,9	26	50,8	41,5	184,2	165	111,1	237	139,7	20,6	120,7	41	31,8	69,9	82,6	49,3
85	73	30	54	43	198	173	124	263	162	29	157	48	38	73	85,7	51,6

Tapped base Plummer block ball bearing units, set screws for metric shafts

d 20 - 85 mm

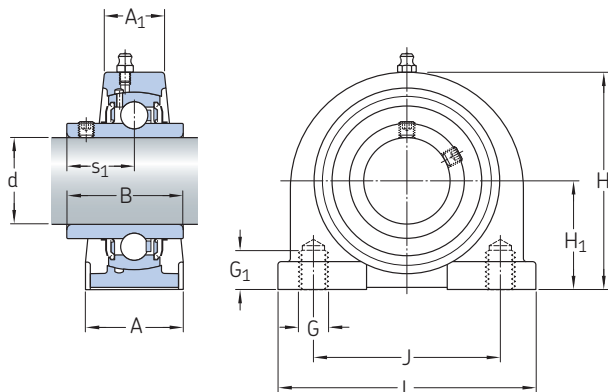

Principal dimensions	Basic load ratings		Fatigue load limit	Limiting speed with shaft tolerance h6	Mass	Designations		Unit
	dynamic	static				Housing	Bearing	
d	C	C ₀	P _u					
mm	kN			r/min	kg	–		
20	12,7	6,7	0,3	6 500	0,54	PA 204	UC 204	UCPA204
25	14,0	7,8	0,3	5 850	0,76	PA205	UC 205	UCPA 205
30	19,5	11,4	0,5	5 000	0,99	PA 206	UC 206	UCPA206
35	25,5	15,3	0,7	4 300	1,46	PA 207	UC 207	UCPA207
40	32,5	20,0	0,9	3 750	1,67	PA 208	UC 208	UCPA 208
45	32,5	20,4	0,9	3 400	1,86	PA209	UC 209	UCPA209
50	35,1	23,2	1	3 300	2,25	PA 210	UC 210	UCPA210

Dimensions

d	H ₁	L	A	J	G	H	G ₁	B	S ₁
---	----------------	---	---	---	---	---	----------------	---	----------------

mm

20	30,2	76,2	34	52	M10X1,5	60	13	31	12,7
25	36,5	84,1	39,5	56	M10X1,5	71	13	34	14,3
30	42,8	93,7	38,9	66	M14X2	84,1	18	38,1	15,9
35	47,6	110,3	42,1	80	M14X2	93	20	42,9	17,5
40	49,2	115,9	44,5	84	M14X2	98	20	49,2	19
45	54,2	119,8	45	90	M14X2	106	25	49,2	19
50	57,2	130,2	50,5	94	M16X2	113	25	51,6	19



[skf.com](https://www.skf.com)

® SKF is a registered trademark of the SKF Group.

© SKF Group 2020

The contents of this publication are the copyright of the publisher and may not be reproduced (even extracts) unless prior written permission is granted. Every care has been taken to ensure the accuracy of the information contained in this publication but no liability can be accepted for any loss or damage whether direct, indirect or consequential arising out of the use of the information contained herein.

PUB BU/P2 17273/1 EN · January 2020